

E-LECTRA / VOLANTE

INSTRUCTION MANUAL

E-lectra 1800
E-lectra 1500
E-lectra 1250
E-lectra 1030
E-lectra 800
E-lectra - S 1350
E-lectra - S 1500

Volante 1800
Volante 1500
Volante 1250
Volante 1030
Volante 800

CONTENTS

EU Directives and UKCA Standards.....3

Important Information and Health & Safety.....4

Components for Electra range..... 5

Built-In Installation..... .6

Side glass installation.....15

Front glass installation..... 17

Suite Installation.....19

Log Layouts.....24

Troubleshooting.....26

Warranty.....28

The following materials and components should be disposed of in accordance with the below table.

Metal - Steel or cast iron	Can be taken to a local recycling centre for reuse to reduce waste going to landfill
Glass & Screens	Can be taken to a local recycling centre for reuse to reduce waste going to landfill.
Vermiculite	Non hazardous material. Vermiculite can be crushed up and used for plant bedding and ash used for composting or disposed of at a local recycling centre for reuse to reduce waste going to landfill.
Electrical components - Fans, heater elements, PCB's, Power pack's, LED's	Dispose at a local recycling centre In accordance with latest WEEE directive.
Log fuel effects	These logs contain refractory ceramic fibre materials which requires disposal in accordance with WEEE legislation.
Natural Wood	Can be taken to a local recycling centre for reuse to reduce waste going to landfill

EU DIRECTIVES

All Evonic Fires products meet the requirements of the EC Directives. These directives have been met by compliance with the following standards:

EU 2011-65/EU 2015/863 Restriction of Hazardous Substances.

References to the relevant designated standards used:

EN 55014-1:2006 + A1:2009 + A2:2011 Electromagnetic Compatibility.

EN 55014-2:2015 Electromagnetic Compatibility.

EN 61000-3-2:2014 Electromagnetic Compatibility (EMC). Limits. Limits for Harmonic Current Emissions.

EN 61000-3-3:2013 Electromagnetic Compatibility (EMC). Limits. Limitation of Voltage Changes, Voltage Fluctuations and Flicker.

EN 60335-1:2012 + A11:2014 Household and similar electrical appliances - Safety

EN 60335-2-30:2009+A11:2012 Household and similar electrical appliances. Safety. Particular requirements for room heaters

UKCA STANDARDS

All Evonic Fires products are in conformity with the relevant UK Statutory Instruments (and their amendments).

2016 No. 1101 The Electrical Equipment (Safety) Regulations 2016

2016 No. 1091 The Electromagnetic Compatibility Regulations 2016

2012 No. 3032 The Restriction Of Use Of Certain Hazardous Substances In Electrical And Electronic Equipment Regulations 2012



IMPORTANT INFORMATION AND HEALTH & SAFETY

When using electrical appliances, basic precautions should always be followed to reduce the risk of fire, electric shock, and injury to persons, including the following:

- Read all of the instructions carefully before using the appliance, only use this appliance as described in this manual. Any other use not recommended by the manufacturer may cause injury to persons, or damage to the appliance.
- Remove all packaging and dispose of it at an appropriate recycling facility.
- When transporting or storing the appliance and power lead, keep in a dry place, away from excessive vibration and store so as to avoid damage.
- This fireplace is hot when in use. To avoid burns, do not let bare skin touch hot surfaces. The trim around the heater outlet becomes hot during heater operation.
DANGER: High temperatures may be generated under certain abnormal conditions.
- Do not install this appliance immediately in front of a fixed socket outlet.
- Do not install this appliance in the immediate surroundings of a bath, shower, swimming pool or any other area where the appliance could come into contact with water or humidity, e.g. a bathroom.
- Do not use in areas where gasoline, paint, or any flammable liquids are used or stored.
- This appliance is only suitable for indoor use, do not use outdoors.
- Do not cover the appliance, or let the air inlet/outlet to be obstructed in any way as it may overheat.
- Keep the power lead away from hot surfaces and the heater outlet. Do not route the power lead in front of the appliance, or under any carpets or rugs. Do not allow the power lead to be coiled up once installed, as this can cause overheating.
- This appliance must be firmly fixed to or recessed into, a flat internal wall.
- A maintenance hatch must be installed into the surrounding installation to allow future access.
- Always use a certified electrician should new circuits or outlets be required. And always use properly grounded, fused and polarised outlets.
- Where the power lead passes through any masonry wall, stone surround etc. ensure that suitable rubber bushes are fitted at any possible wear points.
- If the power lead is damaged do not use the appliance until it has been replaced.
- Do not use any external switching device, timers, or extension leads. Do not connect the appliance to a circuit that is frequently switched on and off by the utility.
- In the event of a malfunction, switch off the appliance, and disconnect it from the mains power supply. Have the appliance inspected by a certified electrician before reusing.
- Do not use the appliance if it is damaged. In the event of any damage to the appliance, please contact the retailer from whom the appliance was purchased.
- Any repairs must only be performed by a certified electrician.
- Extreme caution is necessary when any heater is used by, located near children or people of reduced mobility, and whenever the unit is left operating and unattended.
- Young children should be supervised to ensure that they do not play with the appliance.
- Disconnect from the power supply before performing any cleaning, maintenance or relocation of the unit. Do not use steam cleaners, or aerosols near the appliance.
- Do not burn wood or anything else in this appliance.
- Do not strike the glass. The glass used is toughened safety glass, if broken it will shatter into small chunks which are less likely to cause injury.
- Do not drill or screw any new holes into the appliance.

INSTALLATION

MODEL DIMENSIONS

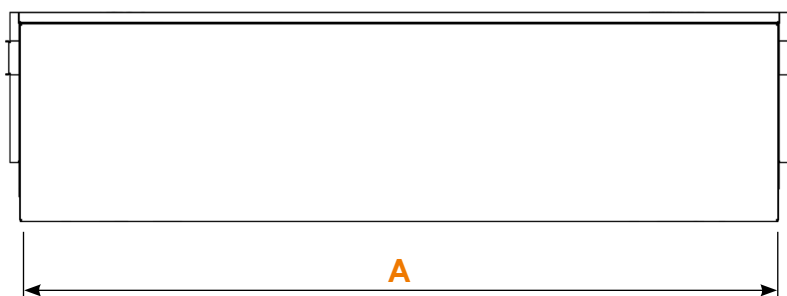

A - Width excl. plaster kit

B - Width incl. plaster kit

C - Opening height

D - Depth excl. plaster kit

E - Height

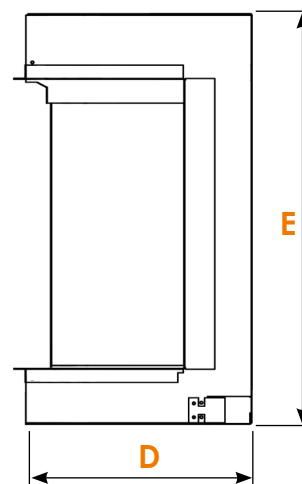
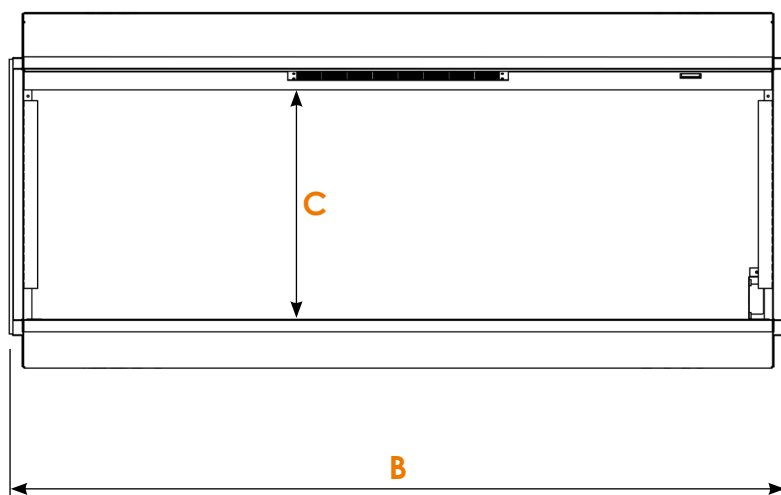

MODEL	A	B	C	D	E
E-lectra 1800	1753mm	1785mm	414mm	300mm	587mm
Volante 1800	1753mm	1785mm	414mm	300mm	587mm
E-lectra 1500	1503mm	1535mm	414mm	300mm	587mm
Volante 1500	1503mm	1535mm	414mm	300mm	587mm
E-lectra 1250	1253mm	1285mm	414mm	300mm	587mm
Volante 1250	1253mm	1285mm	414mm	300mm	587mm
E-lectra 1030	1002mm	1034mm	414mm	300mm	587mm
Volante 1030	1002mm	1034mm	414mm	300mm	587mm
E-lectra 800	804mm	836mm	587mm	300mm	762mm
Volante 800	804mm	836mm	587mm	300mm	762mm
Electra-S 1350	1300mm	1300mm	414mm	325mm	636mm
Electra-S 1500	1500mm	1500mm	414mm	355mm	636mm

For detailed
specification
drawings
please scan
the QR code



CONVERTING TO GF / GF2 / GF3

The appliance is shipped in the GF3 configuration, however all models can be converted to be GF or GF2 depending on your preference.

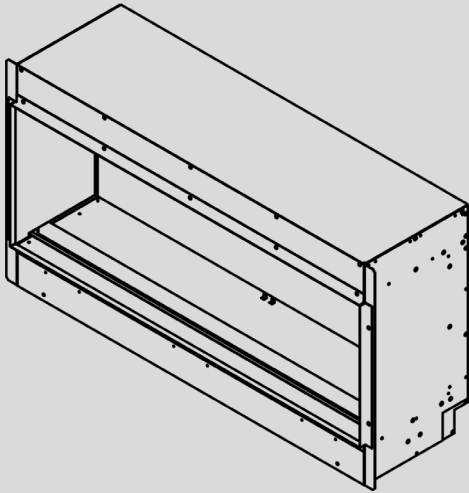

GF Configuration

Glass Fronted

A single glass panel at the front of the appliance.

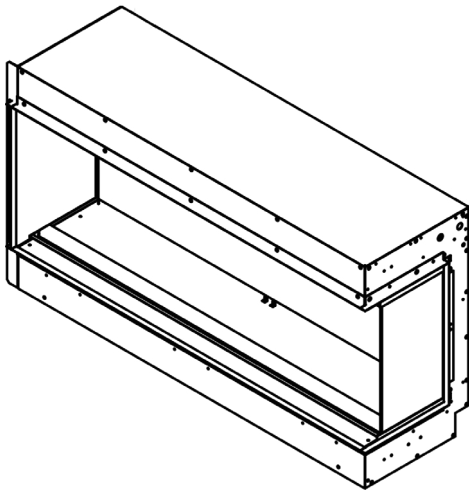

GF2 Configuration

Glass Fronted 2

A glass panel at the front and one side piece of glass. The glass can be either side.

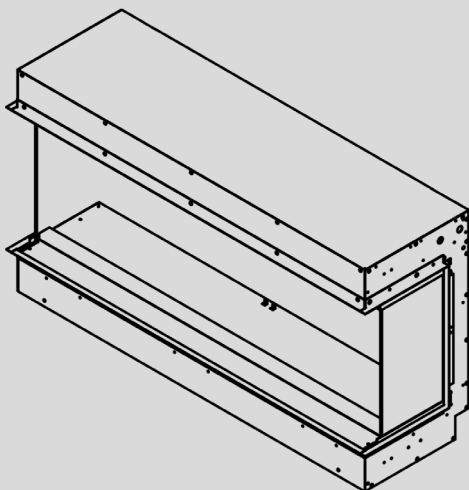

GF3 Configuration

Glass Fronted 3

The standard configuration.

A glass panel at the front and both side pieces of glass.

INSTALLING THE SIDE PANELS / CONVERTING TO GF / GF2

1

Unscrew and remove the plaster kits from the side/s of the appliance.

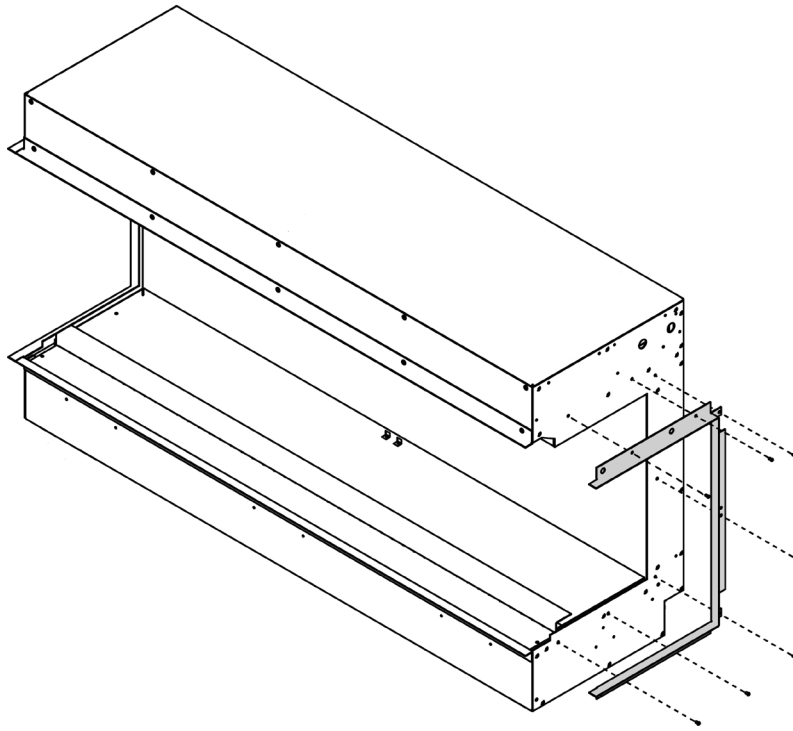

2

Screw in the side panel/s, on one or both sides.

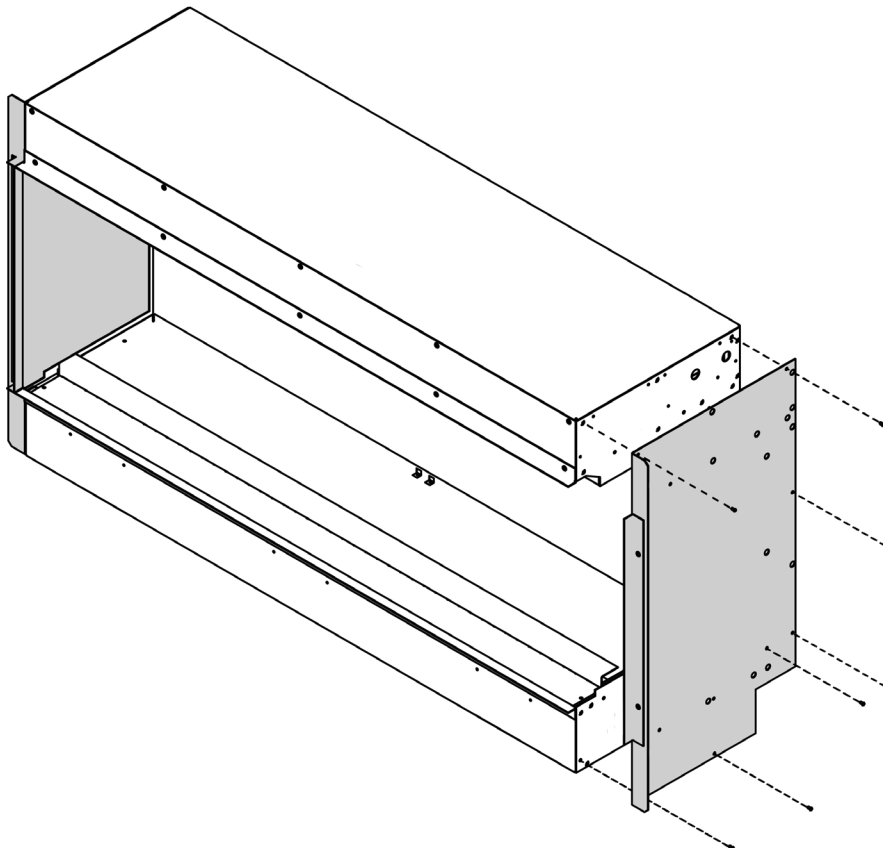

INSTALLATION

INSTALLATION REQUIREMENTS

Before installing the appliance please read and take into account the following important requirements;

- Consult a qualified professional to check the structure of the installation site.
- These appliances have been designed to be installed into either a stud and plasterboard wall, or an existing chimney breast. (Please note that Open, GF2, and GF3 models are not suitable for existing chimney breast installations.)
- If installing into an existing chimney, make sure to adequately block off the flue.
- The appliance must never be installed in front of an electrical socket.
- The appliance must not be installed anywhere that it may come into contact with water, i.e. a bathroom.
- Do not wet plaster directly onto the appliance.

CHECKS BEFORE INSTALLATION

We recommend turning on the appliance before installation, connect the appliance to a power source using the provided electrical lead, and depress the right side of the rocker switch.

Remove the electrical lead from the wall and continue with the installation.

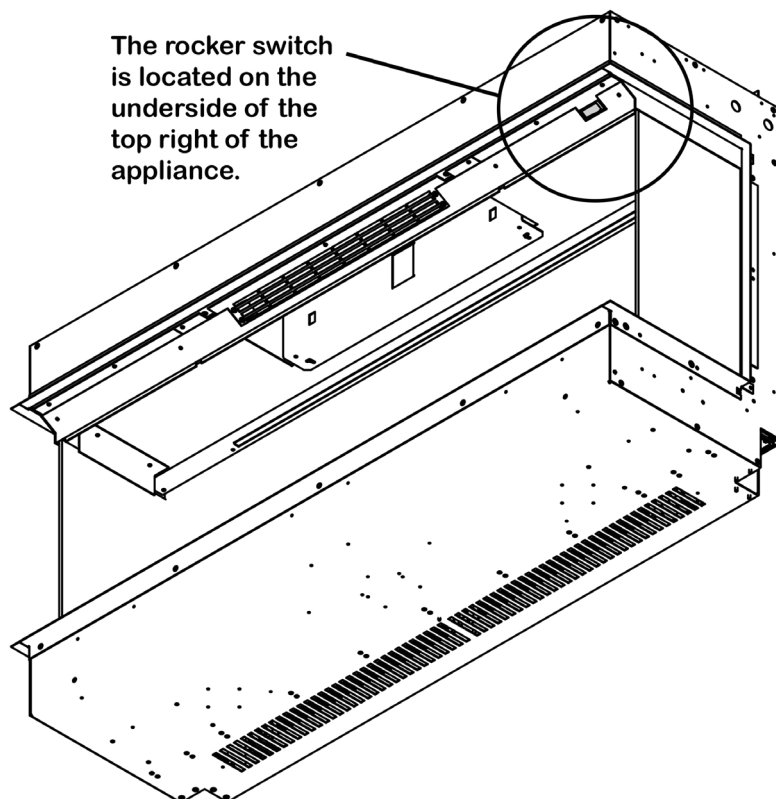
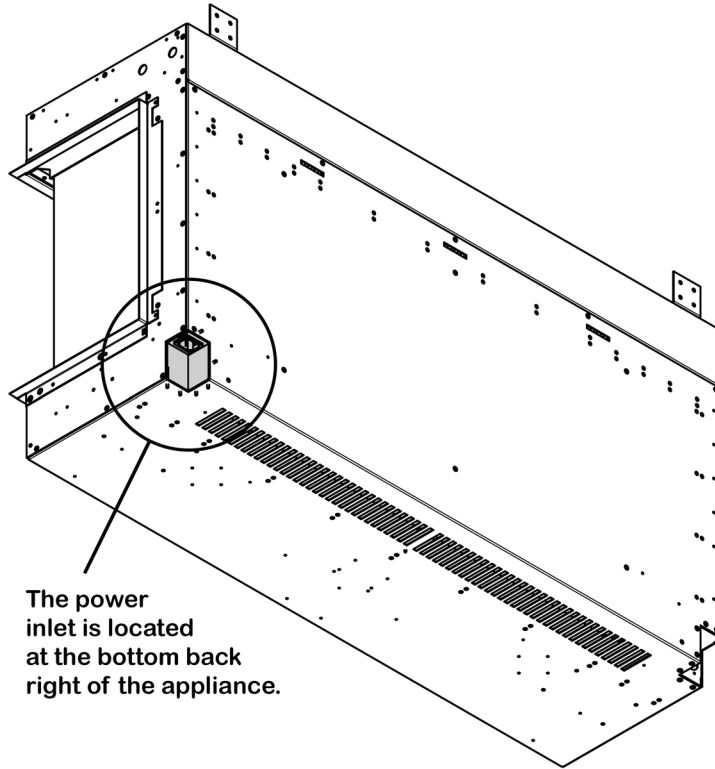

INSTALLATION STEPS

1

Remove the bottom transit brackets, and side brace bars. Then screw on the top mounted brackets, and the IEC Clip on the back right.

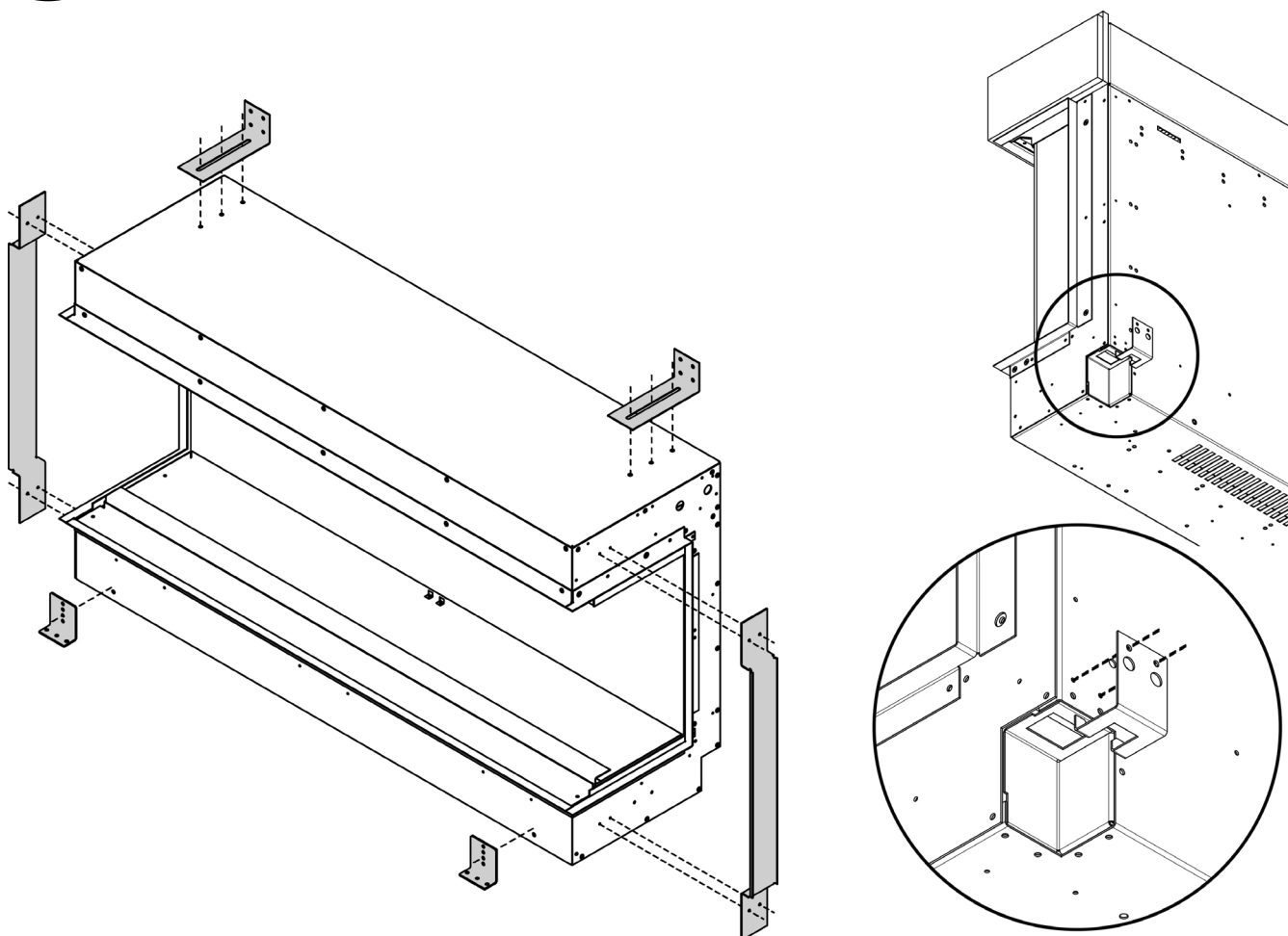

2

Screw the two top mounted brackets to the wall.

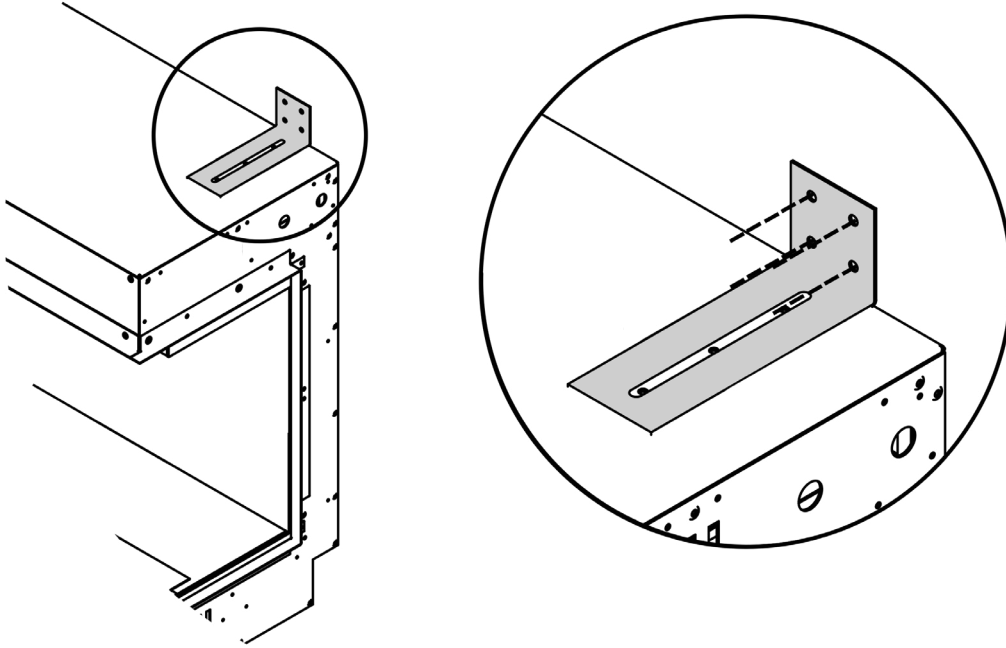

3

You can now construct your stud wall/s around the appliance in the design of your choosing.

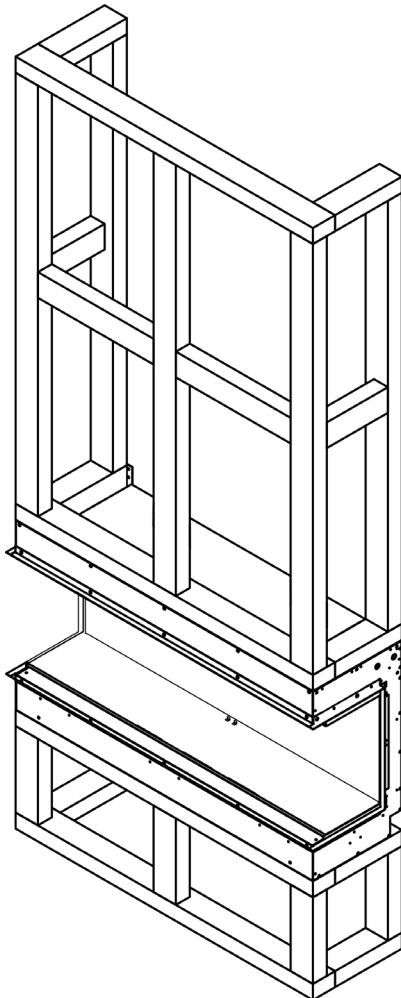

When constructing the studwork, remember that the vents on the underside of the appliance need a minimum of 50mm clearance beneath them.

Ensure that the appliance isn't supporting the weight of the studwork.

Do not use silicones, adhesives, or wet plaster to seal in the appliance.

Before plasterboarding in the appliance it is recommended that you create a maintenance hatch for future access.

4

Your plasterboard can now line up with the plaster kits on the edge of the appliance.

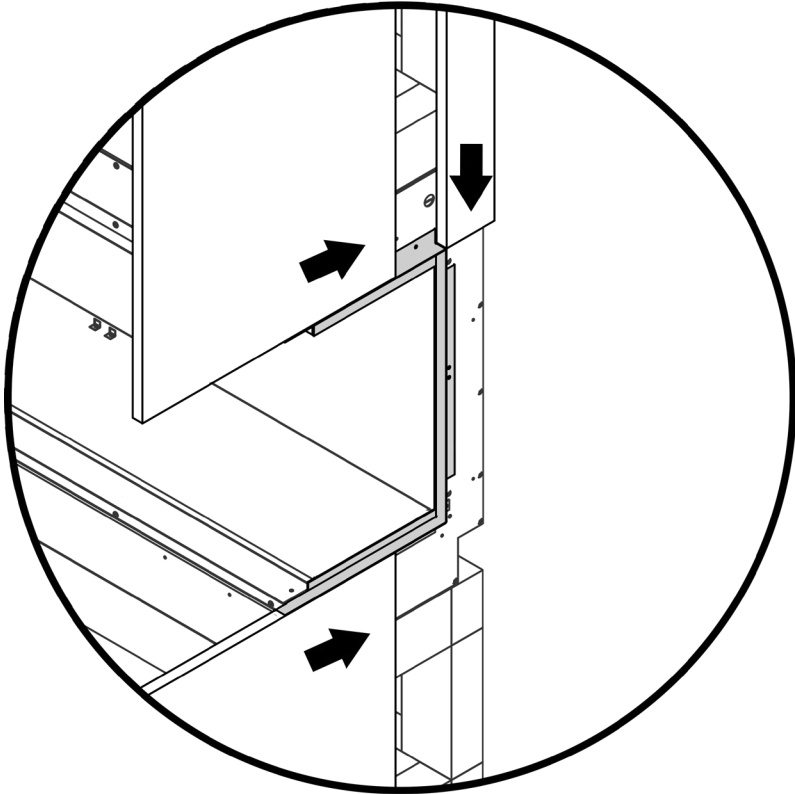

5

Alternatively, the optional chrome side panels can be attached to the case with the magnets as shown below.

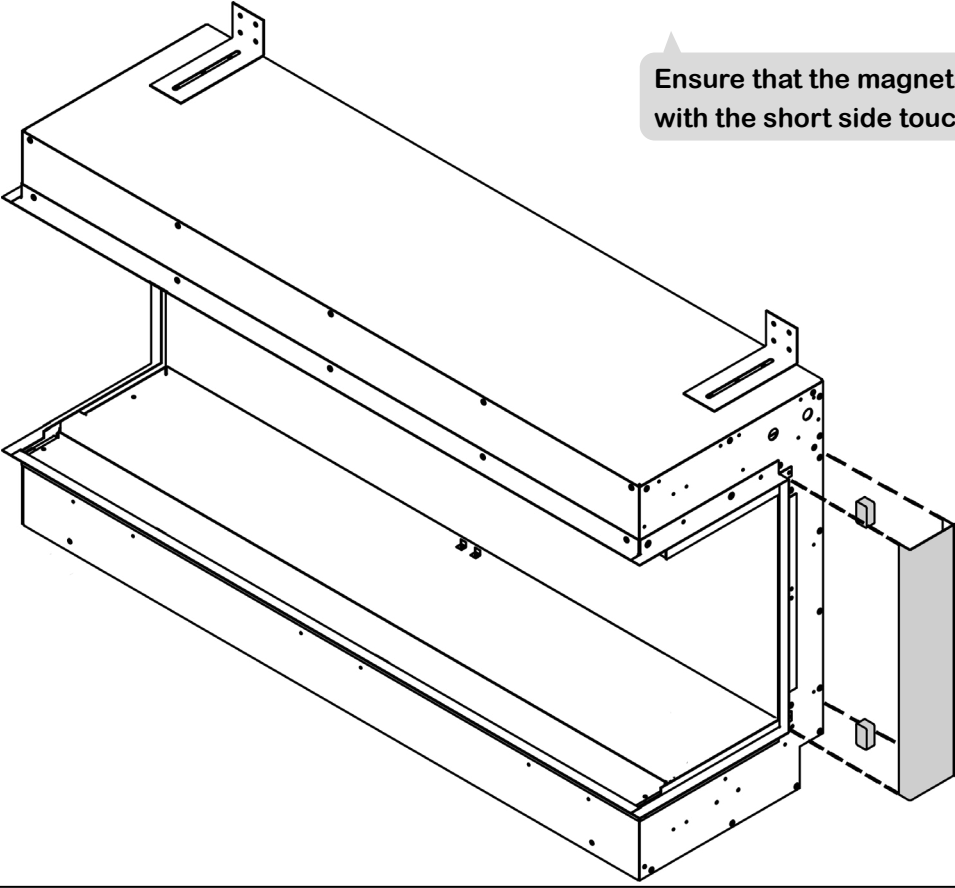

Ensure that the magnets are positioned with the short side touching the case.

INSTALLING THE SIDE GLASS PANELS

INSTALLING THE SIDE GLASS PANELS

1

Unscrew and remove the top and bottom glass retainer panels.

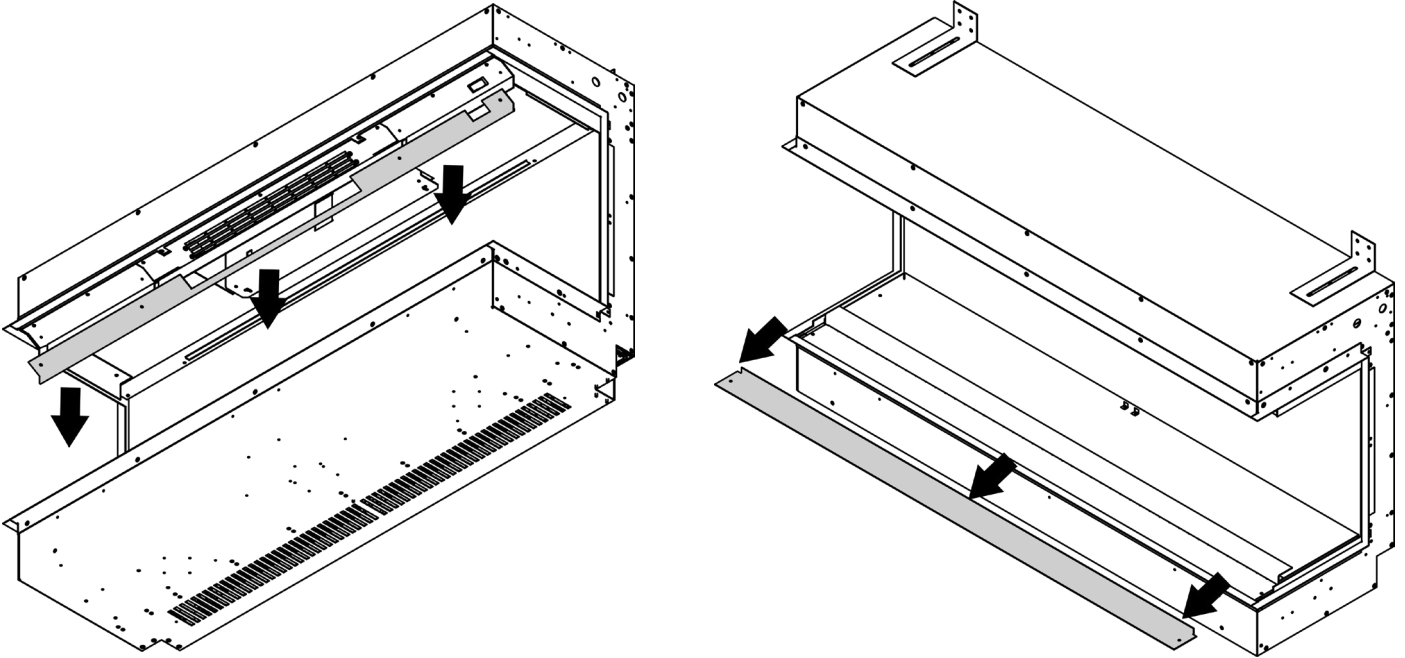

2

Slide in the side glass pieces.

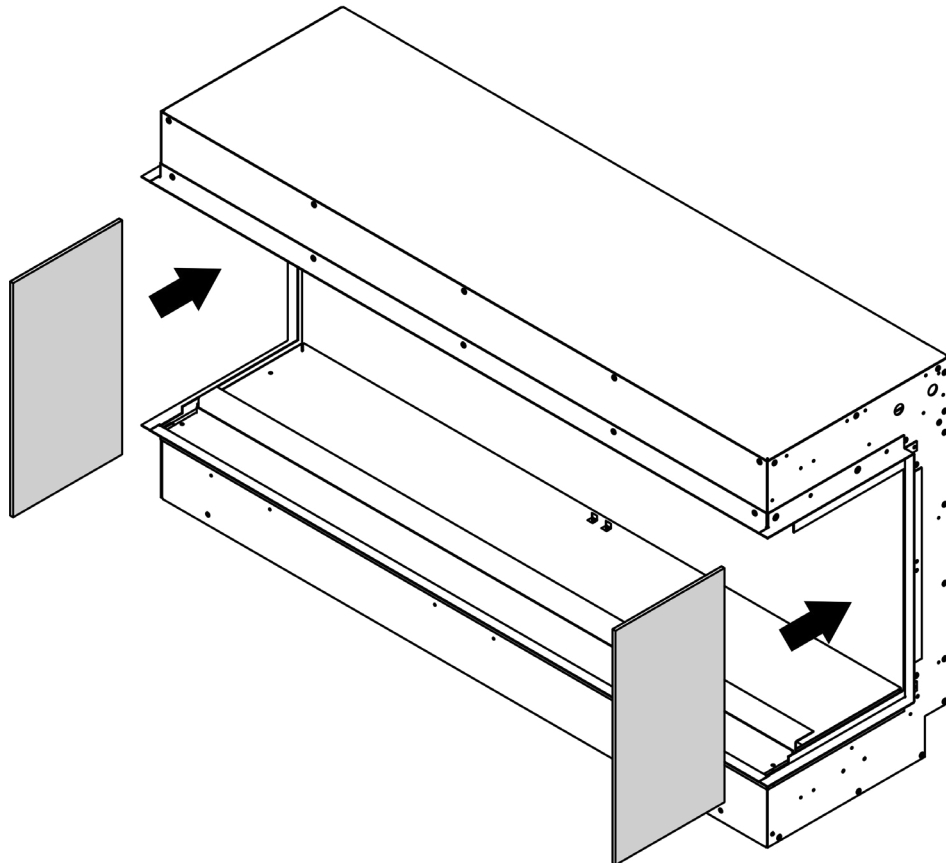

INSTALLING THE FRONT GLASS PANEL

Please Note: The glass suction pad comes with models Volante 1800 and e-lectra 1800. On all other models, the glass suction pad is an optional extra.

INSTALLING THE FRONT GLASS PANEL

If using a glass sucker, apply the Suction Lifter to the glass and position the bottom edge of the glass first, then pivot the glass into the appliance. If not using a glass sucker, carefully hold the glass on either end and follow the same process. 2 people may be required for this to ensure the glass is carefully supported at all times.

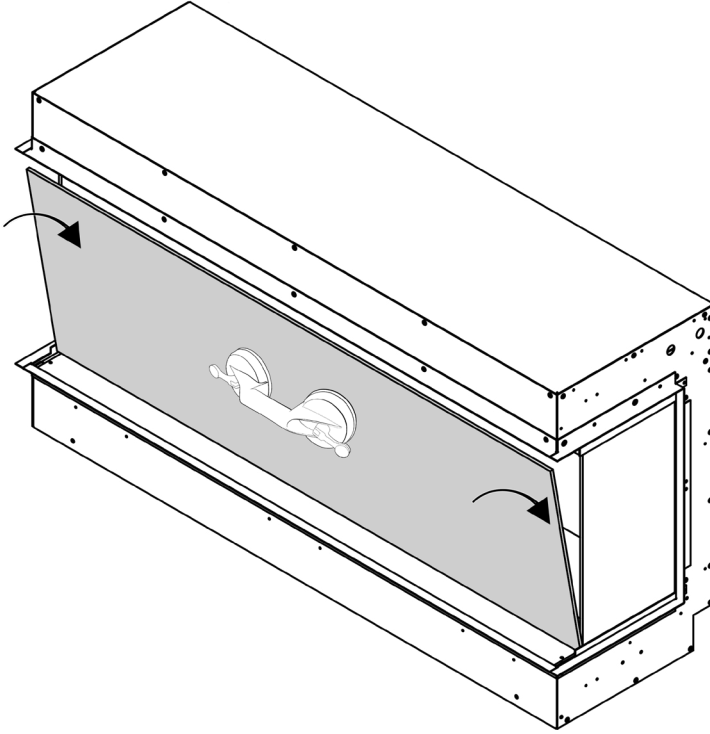

Warning

The Suction Lifter is provided to assist in moving the glass **NEVER** as the sole support of the glass. Always support the glass throughout the entire process until the glass is fully fitted. The glass is toughened safety glass and if broken will shatter into many small chunks.

Then replace the top and bottom glass retainers.

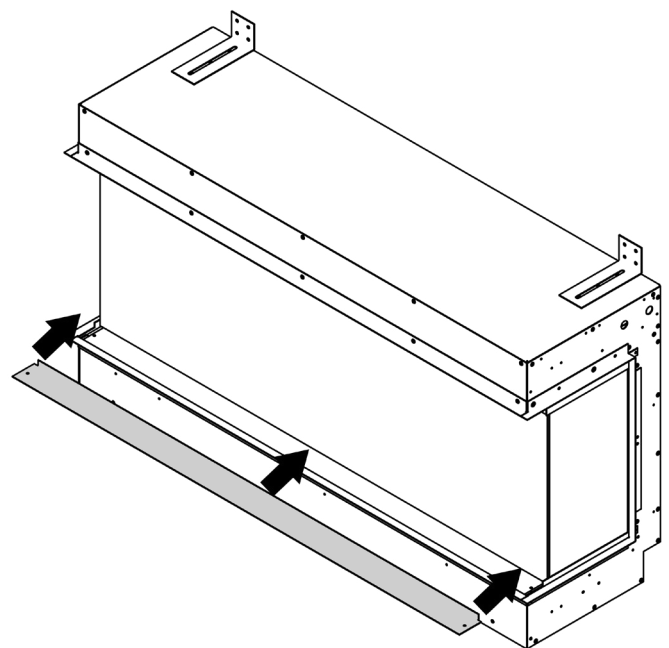
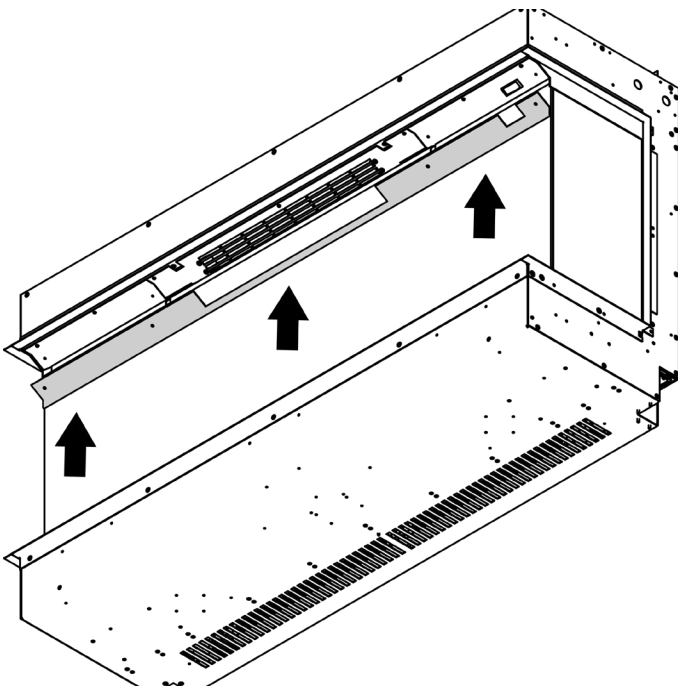

INSTALLATION

E-LECTRA S-1350

E-LECTRA S-1500

INSTALLATION REQUIREMENTS

Before installing the appliance please read and take into account the following important requirements;

- The appliance must never be installed in front of an electrical socket.
- The appliance must not be installed anywhere that it may come into contact with water, i.e. a bathroom.
- The minimum height above the finished floor level is 300mm.

CHECKS BEFORE INSTALLATION

We recommend turning on the appliance before installation, connect the appliance to a power source using the provided electrical lead, and depress the right side of the rocker switch.

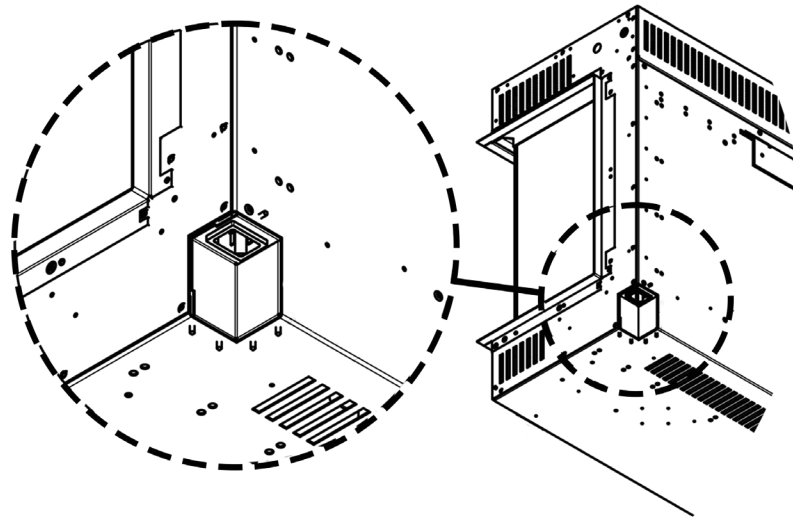

Power socket

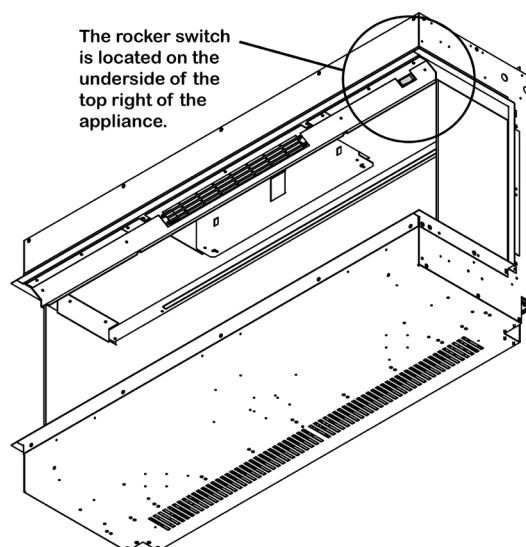

Rocker switch

TOOLS REQUIRED

- Tape Measure
- Pencil
- Spirit Level
- Screwdriver
- PZ2 Screw Bit
- Drill Bit
- Wall Plugs (Masonry type supplied)
- Wall Screws (Masonry type supplied)
- Stud Detector (For plasterboard installations only)
- Wall Anchors (For plasterboard installations only. Not supplied)

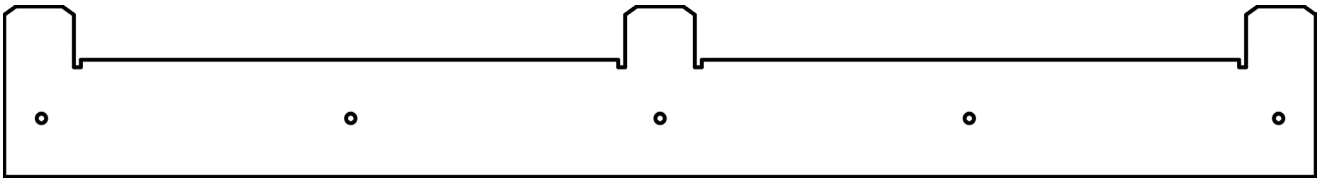

The appliance is supplied with a wall bracket, shown above.

INSTALLATION STEPS

1

Remove the bottom mounted transit brackets, you won't need these for installation. Then screw on the IEC Clip to the bottom back of the case, with the two provided screws.

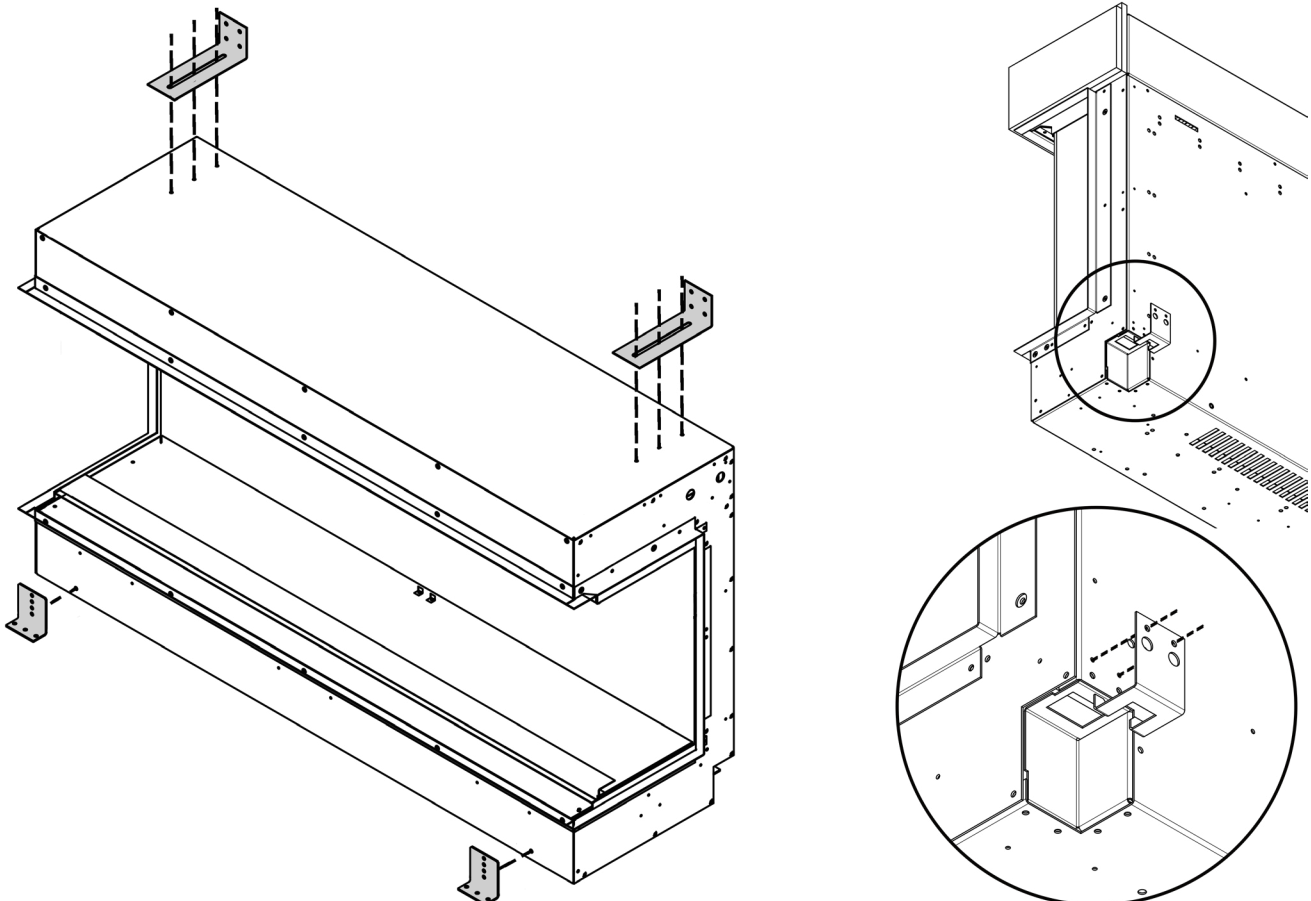

2

Determine the finished height and position that you want the appliance to be located. Then secure the wall bracket to the wall in the position you need using the wall plugs and screws provided. If you're not securing the appliance to a masonry wall you will need to use the appropriate fixings.

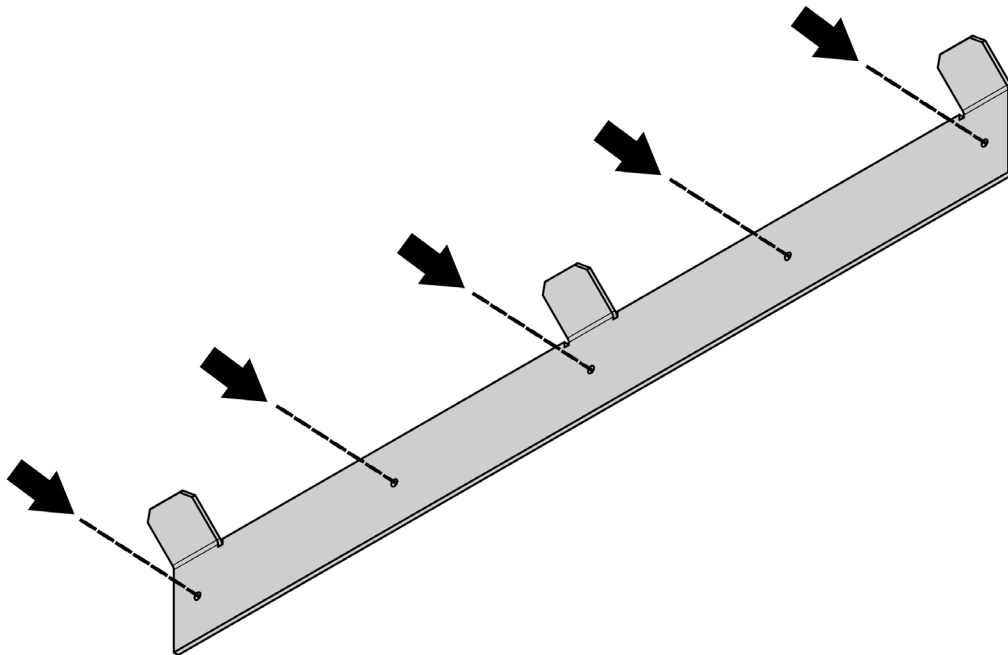

3

Slide the appliance into the woodwork, and screw through the pre-attached brackets as shown.

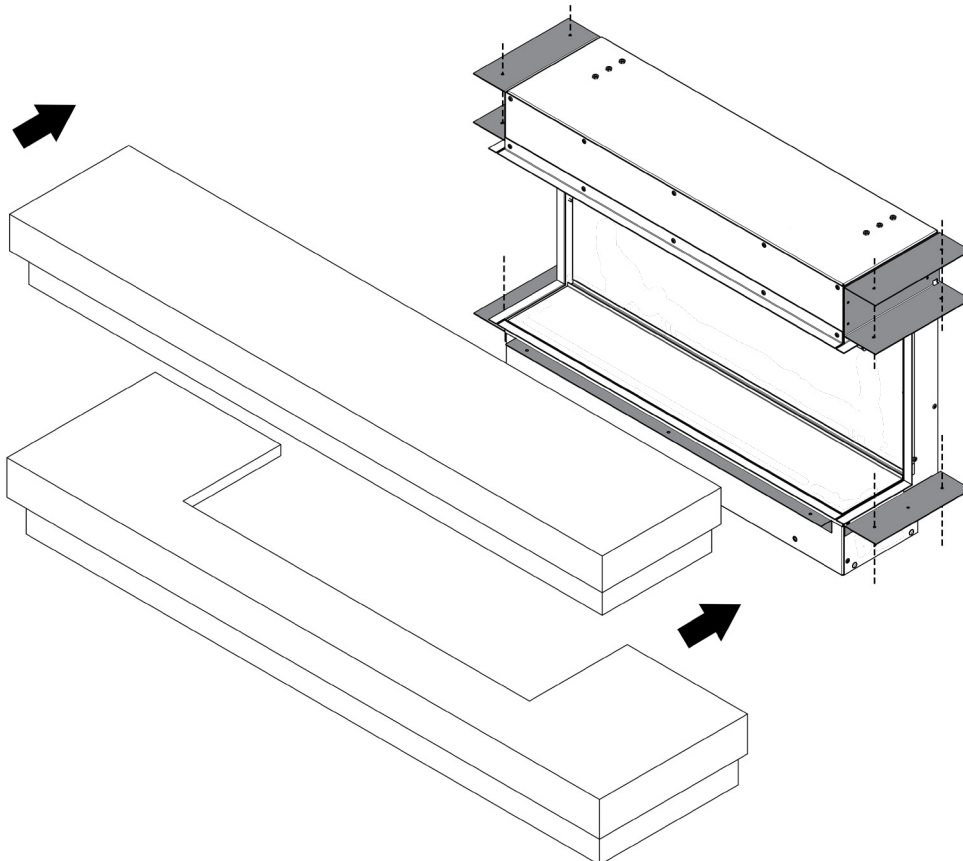

4

You can now hang the appliance on the wall by slotting the tabs of the wall bracket into the slots on the back of the appliance. Connect the appliance to the mains power supply and it is ready to use.

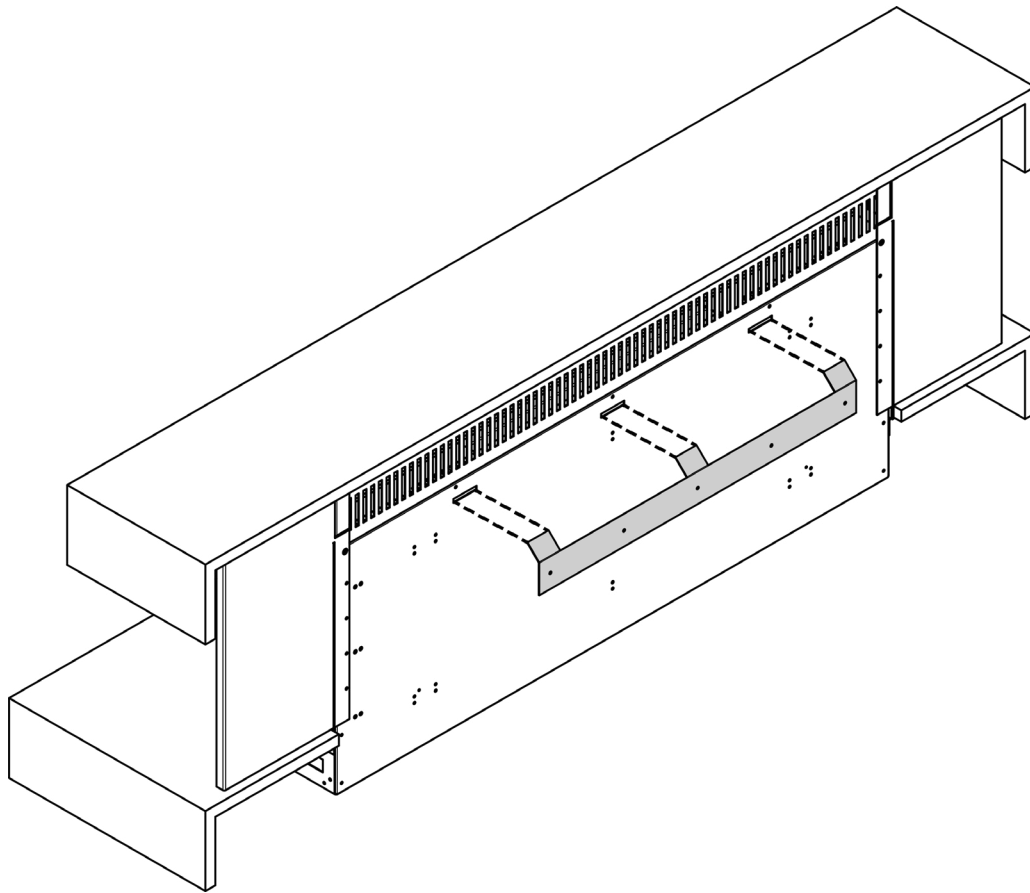

LOG LAYOUTS

LOG LAYOUTS

When you have your appliance installed you can set up your log set/s. Lay the coconut husk on the fuel bed first, then continue with laying out your logs. There is no right or wrong way to arrange your logs, the following images are an example of how you could lay them out.



E-lectra S 1350/1500 log set



E-lectra & Volante 800 / 1030



E-lectra & Volante 1250 / 1500



E-lectra & Volante 1800

TROUBLESHOOTING



Heater Access & Replacement

Scan the QR code to be taken to a video in our maintenance series.

Please note; this video shows an old method of removing the front glass panel. Refer to page 24 of this instruction manual for the new method.



E-Smart Only

E-Smart LED Replacement

Scan the QR code to be taken to a video in our maintenance series.

Please note; this video shows an old method of removing the front glass panel. Refer to page 24 of this instruction manual for the new method.

REPORT A FAULT



If you have any difficulties or problems with your appliance then please get in touch so that we can assist you. Please scan the QR code to be taken to our websites Report a Fault page, we will then be in touch with you shortly.

WARRANTY

Evonic Fires 5-year warranty – 1 year parts & labour + 4 years parts supplied.

The above warranty terms and conditions, as of **1st May 2022**, are applicable for all relevant products purchased after this date. Appliances despatched prior to this date will have an alternative warranty as set out within the Installation and User Instructions that was supplied with the product, this was usually a standard 2-year warranty.

To receive your Extended Warranty your Evonic Fires product must have been purchased from an authorised stockist within our Retailer Network and your warranty registered with Evonic Fires through the online form - **evonicfires.co.uk/register-your-product**. The commencement date for the warranty period is the date of purchase.

The product must be adequately serviced and maintained. Evonic Fires provide maintenance call outs at a cost, and information on this can be obtained by contacting our head office. Please see your Evonic Installation Instructions for further information on how to service and maintain your appliance.

During your extended warranty period, only parts supplied or authorised by Evonic Fires can be used to repair your fireplace, and these spare parts can be obtained by contacting our service department at **service@evonicfires.co.uk** or calling **01789 263868**.

Consumable items such as glass, screens, LED's, LED boards, filters and power supplies which are either subject to normal wear and tear or parts that require replacement in connection with normal maintenance are not covered within the extended warranty. These items are covered for the first 12 months.

To make a warranty claim, evidence must be supplied to our service department in the form of pictures, videos, or both. Failure to supply evidence to support your warranty claim may invalidate or delay the claim. Any visit by an Evonic Fires engineer will incur a service charge after the first year. We will not accept or reimburse the cost(s) of any third party who undertakes any work carried out on the product or fits parts, unless we have approved such work in advance of it being carried out.

WARRANTY EXCLUSIONS AND LIMITATIONS

The Evonic Extended Warranty does not cover:

1. Damage resulting from installation and usage where the appliance has not been installed or used in accordance with the CK Fires Ltd installation and operation instructions, or if the installation does not conform to local building, fire, and safety regulations.
2. Issues with mains/spur connections of power supply.
3. Damage resulting from the product not being adequately maintained. (Please see your CK Fires Ltd Installation and Operating Instructions for further information on how to service and maintain your appliance).
4. Damage caused by unauthorised modifications, use or repair.
5. Damage or defects caused by the product being stored in a damp, unheated environment.
6. Consequential loss (to the extent permitted by the law) relating to other associated products that have not been supplied by CK Fires Ltd.
7. Consequential loss (to the extent permitted by law) related to decorations, furnishings, or other household assets.
8. Removal and re-installation costs.

WARRANTY EXCLUSIONS AND LIMITATIONS

Repaired or replaced products are covered only for the remainder of the original warranty period. In the event of a claim being made, this must be reported to your retailer or CK Fires Ltd within 14 days of the fault occurring/being noticed. In the event of a product fault occurring during the warranty period years 2-5, CK Fires Ltd will send the appropriate component or goods necessary to rectify the fault, free of charge.

Nothing in the Extended Warranty shall make CK Fires Ltd liable for any or special, incidental, or consequential damages, injury to persons or property, or any other consequential loss beyond the consumer's statutory rights. The liability on these issues is covered by our Terms and Conditions of Sale.

CK Fires Ltd total liability extends only to the purchase price paid for the goods, except where such a limitation is prohibited by statute. CK Fires Ltd, in the event of a warranty claim, reserves the right either to replace the goods in question or to refund the purchase price of the goods. For product sold outside the UK and Ireland, UK law will prevail. The Evonic Fires Extended Warranty does not affect your statutory rights.

CK Fires Ltd / Evonic Fires

**1, Evonic House, Clifford Park, Clifford Lane,
Stratford-on-Avon, CV37 8HW**

**Tel: +44 (0)1789 263868 Fax: +44 (0)1789 293080
Email: sales@evonicfires.co.uk
www.evonicfires.co.uk**

**Follow us on:
Instagram | Facebook | Twitter | LinkedIn
[@evonicfires](#)**