



WF35 Insert

UK: INSTALLATION MANUAL AND OPERATING
INSTRUCTIONS

WESTFIRE

DANSK INGENIØRKUNST

WF35

PRODUCT SHEET

Energy Labelling Directive – (EU)2015/1186 for Solid Fuel Boilers and Packages of Solid Fuel Boilers, Supplementary Heaters, Temperature Controls and Solar Devices

Gemäss Verordnung (EU) 2015/1186

Fiche de produit conformément au règlement (EU) 2015/1186

Product	Westfire ApS
Model	Westfire 35 insert
Energy Efficiency Class	A
Nominal Heat Output to Room	4.6 kW
Nominal Heat Output to Water	0 kW
Seasonal Space Efficiency (EEI)	104
Net Efficiency	78%
Specific precautions when installed or maintained	See the Instructions manual

WESTFIRE

WESTFIRE 2020 | WF35



WF35

UK: INSTALLATION MANUAL AND OPERATING INSTRUCTIONS

Declaration of performance according to Regulation (EU) 305/2011

No. 300-ELAB-2436-EN

PRODUCT

Type Wood burning insert Westfire 35
 Trade name Heating of rooms in residential buildings
 Intended area of use Fuel Wood

MANUFACTURER

Name Westfire APS
 Address Tømmervej 3
 6800 Varde, Denmark

VERIFICATION

According to DANAK System 3
 European standard Test EN 13229:2001/A2:2004/AC:2007
 institute Danish Technological Institute

DECLARED PERFORMANCE

ESSENTIAL CHARACTERISTICS	PERFORMANCE	HARMONISED TECHNICAL SPECIFICATION
Fire safety	Pass	EN 13229:2001/A2:2004/AC:2007
Fire classification	A1	
Minimum distance to flammable materials	Rear: 200 mm (With heat shield) Side: 200 mm (With heat shield) Ceiling: 800 mm Front: 1000 mm Floor: 300 mm Corner: 150 mm	
Fire hazard due to burning fuel falling out	Pass	
Cleanability	Pass	
Emissions from combustion	CO: 0.1069%	
Surface temperatures	Pass	
Temperature on the handle	NPD	
Mechanical resistance	Pass	
Temperature in the space for wood storage	NPD	
Nominal output	4,6 kW	
Efficiency	78,2%	
Flue gas temperature at nominal output	260 °C	
Flue gas temperature in flue spigot	311 °C	

Contents

PAGE

ITEM

2 - 17

Technical Data and Installation manual

18 - 30

Operation and Maintenance Instructions

INSTALLATION MANUAL AND OPERATING INSTRUCTIONS

WF35 INSERT WITH 3 SIDED FRAME

WF35 INSERT WITH 4 SIDED FRAME

This manual refers to the stove listed above, which is tested in accordance with EN 13240.

Thank you for purchasing your new stove from Westfire Stoves. Please read this manual carefully to ensure that you get maximum enjoyment and performance from your new stove and to prevent any potential operational problems. Please note that "all local regulations, including those referring to national and European Standards, need to be complied with when installing this appliance". For further information on installing and using fireplaces and wood burning stoves, please see the relevant building regulations.

These instructions cover the basic principals to ensure the satisfactory installation of your multi-fuel stove, although detail may need slight modification to suit particular local site conditions.

Dimensions (mm)	Stove Width	Stove Depth	Stove Height	*Height to centre line 45° spigot	Frame Height	Frame Width	Weight kg
Model							
WF35 insert 4 Sided Frame	392	345	555	525	590	480	80 kg
WF35 insert 3 Sided Frame	392	345	555	525	625	480	80 kg

3 Sided Frame

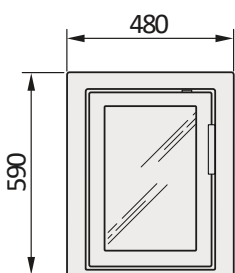

Side View Vertical Exit

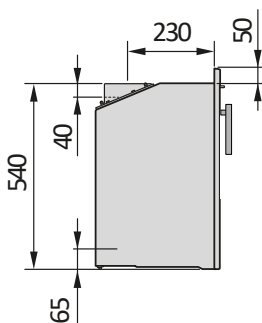

Top View

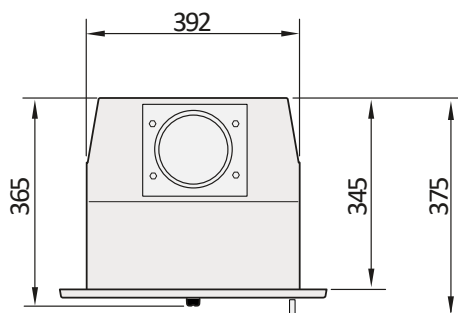

4 Sided Frame

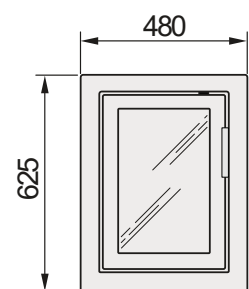

Side View 45° Exit

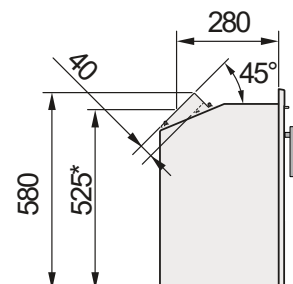
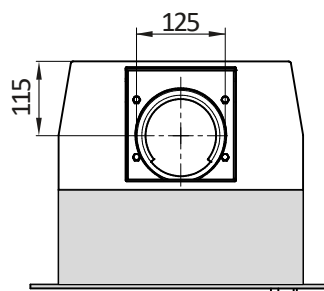

STOVE PERFORMANCE & TESTING

WF35 models are tested in accordance with EN 13240.

	Output wood fuel	Efficiency	CO@13% O ₂	Recommended for smoke control Oct 2016	Output coal fuel	Efficiency	CO@13% O ₂
WF35	4.6kW	78.2%	0.10	Yes / SE model	3.7kw	76%	0.17

Stove model: Weight & Nominal heat output for wood and smokeless fuels

	Log length	Wood reload	Weight wood load	Coal reload	Weight coal (anth)
WF35 insert	300mm	1hr	1.2kg	2hr	1.1kg

Distance to Combustible materials

Combustible materials should not be located where the heat dissipating through the walls of fireplaces or flues could ignite it. Therefore when installing the stove in the presence of combustible materials due account must be taken of the guidance on the separation of combustible material given in Building Regulations Approved Document J and also in these stove instructions. The minimum distances to flammable materials are specified on the EN 13240 plate on the back of the stove.

	Distance to Combustibles rear	Distance to Combustibles sides	Distance to combustibles sides Convection models	Suitable for 12mm non-combustible floor plate
WF35	200mm	200mm	n/a	N/a

BUILD IN DIMENSIONS

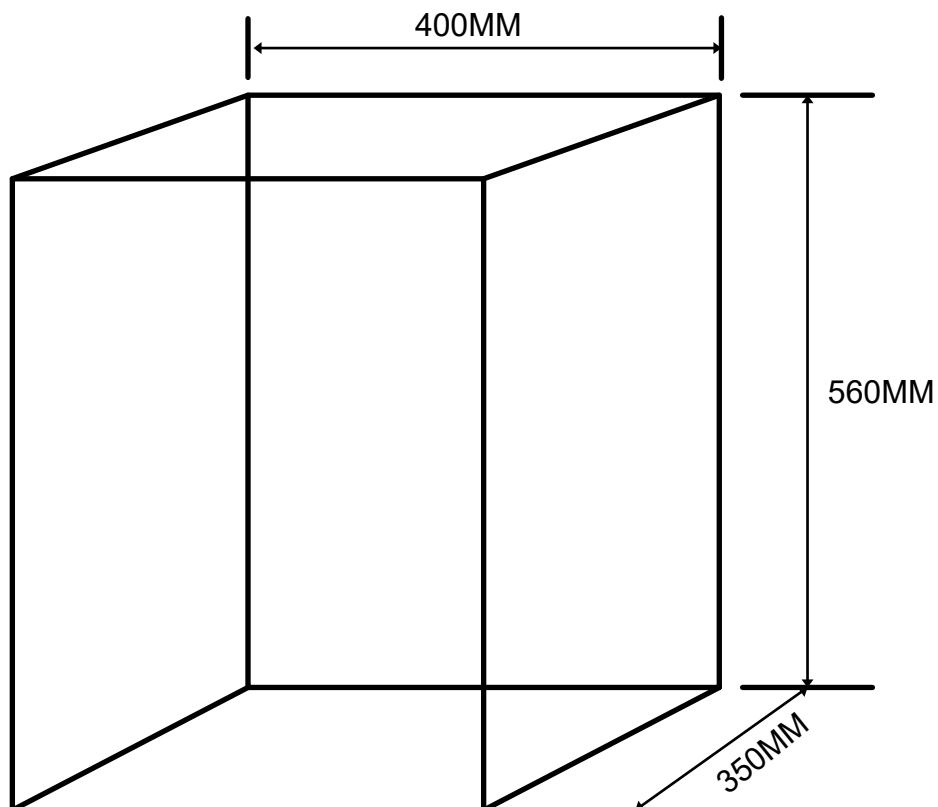

HEALTH AND SAFETY PRECAUTIONS

INFORMATION FOR THE USER, INSTALLER AND SERVICE ENGINEER

Special care must be taken when installing a stove such that the requirements of the Health & Safety at Work Act are met.

Handling

Adequate facilities must be available for loading, unloading and site handling.

Fire Cement

Some types of fire cement are caustic and should not be allowed to come into contact with the skin. In case of contact wash immediately with plenty of water.

PREPARATORY WORK AND SAFETY CHECKS

IMPORTANT WARNING

This stove must not be installed into a chimney that serves any other heating appliance. There must not be an extractor fan fitted in the same room as the stove because this can cause the stove to emit fumes into the room.

Asbestos

This stove contains no asbestos. If there is a possibility of disturbing any asbestos in the course of installation then please seek specialist guidance and use appropriate protective equipment.

Metal Parts

When installing or servicing this stove care should be taken to avoid the possibility of personal injury.

CO Alarms:-

Building regulations require that whenever a new or replacement fixed solid fuel or wood/biomass appliance is installed in a dwelling a carbon monoxide alarm must be fitted in the same room as the appliance. Further guidance on the installation of the carbon monoxide alarm is available in BS EN 50292:2002 and from the alarm manufacturer's instructions.

Provision of an alarm must not be considered a substitute for either installing the appliance correctly or ensuring regular servicing and maintenance of the appliance and chimney system.

Stove Paint Aerosols

Paint aerosols are flammable and therefore dangerous to use around a lit stove. Be sure to allow aerosols spray paints to dry and ventilate the room well before lighting the stove. The use of any aerosol around lit stove is dangerous and care must be taken in handling aerosols.

IMPORTANT:

These instructions cover the basic principles to ensure the satisfactory installation of Westfire Stoves product :- WESTFIRE 35 models, although detail may need slight modification to suit particular local site conditions. In all cases the installation must comply with current Building Regulations, Local Authority Byelaws and other specifications or regulations as they affect the installation of the stove.

It should be noted that the Building Regulations requirements may be met by adopting the relevant recommendations given in British Standards BS 8303, BS EN 15287 as an alternative means to achieve an equivalent level of performance to that obtained following the guidance given in Approved Document J.

Advise all persons as to the stove's high surface temperatures, including visitors. If it is possible for children or infirm adults to come into contact with the stove, fit a suitable fire guard. The glove supplied with the stove MUST always be worn when opening the door handle and loading fuel onto the stove. The glass on the stove is ceramic glass and able to withstand very high temperatures however it is not toughened and a hard impact could cause the glass to break.

FLUE & CHIMNEY CONNECTION TO STOVE

The outlet from the chimney should be above the roof of the building in accordance with the provisions of Building Regulations Approved Document J. If installation is into an existing chimney then it must be sound and have no cracks or other faults which might allow fumes into the house. Older properties, especially, may have chimney faults or the cross section may be too large .

Westfire Stoves recommend the use of a solid fuel flue lining system for all installation into existing chimneys. All chimney systems must be used in accordance with Building Regulations Approved Document J.

If an existing chimney is used the chimney must be clear of obstruction and be swept clean immediately before installation of the stove. The chimney should be tested to confirm the chimney will provide the correct chimney pressure for the stove. If the stove is fitted in place of an open fire the chimney should be swept one month after installation to clear any soot falls which may have occurred due to the difference in combustion between the stove and the open fire. If there is no existing chimney then either a prefabricated block chimney in accordance with Building Regulations Approved Document J or a twin walled insulated stainless steel flue to BS 1856-1 . These chimneys must be fitted in accordance with the manufacturer's instructions and Building Regulations. A single wall metal flue pipe is suitable for connecting the stove to the chimney but is not suitable for using for the complete chimney. The connecting flue pipe must have a minimum diameter of 125 mm and its dimension should be not less than the size of the outlet socket of the stove. Registered smoke exempt models burning wood only can be installed on flue of 125mm throughout. Any bend in the chimney or connecting flue pipe should not exceed 45°. 90° bends should not be used other than within 150 mm of stove rear flue outlet.

Chimney Connection

In order for the stove to perform satisfactorily the chimney height must be sufficient to ensure an adequate draught to clear the products of combustion and prevent smoke problems into the room.

Tested Gas flow rates flue gas temperatures	Flue gas flow rate Wood /coal	Test flue gas temperature wood /coal	@ pascals of pressure
WF35 insert	4.0/4.7g/sec	244/240 deg C	12 pa

A chimney height of not less than 4.5 metres measured vertically from the outlet of the stove to the top of the chimney should be satisfactory. Alternatively the calculation procedure given in BS5854:1980 may be used as the basis for deciding whether a particular chimney design will provide sufficient draught.

If it is found that there is excessive draught in the chimney then either an adjustable flue damper or alternately a draught stabiliser should be fitted. The adjustable flue damper should not close off the flue entirely but should in its closed position leave a minimum continuous opening free area of at least 20 % of the total cross sectional area of the flue or flue pipe.

Adequate provision e.g. easily accessible soot door or doors must be provided for sweeping the chimney and connecting flue pipe.

Your appliance needs to be maintained routinely, the throat plate/baffle should be cleaned regularly (monthly) . The flue pipe can be cleaned using a flexible brush. Only Use a dry cloth on external surfaces. Over time the glass may become dirty, clean with a damp cloth and polish off with damp cloth. If the stove has not been used for some time the flue should be checked for blockages before use. Do not modify the appliance; only use spares authorised by the manufacturer.

INSTALLATION INSTRUCTIONS

Each installation is unique to the property so it is not possible to give details to suit every setting. The installation must comply with local and national Building Regulations and be made using best practice construction methods.

Many fireplace openings have a supporting lintel. Do not remove without supporting the remaining structure of the building. Do not support the structure with the flue system or the appliance.

The flue system must be fully installed and supported according to the manufacturer's instructions BEFORE the appliance is installed.

1a Take care when installing the appliance. Careless handling and use of tools can damage the finish and/or area.

1b Remove all internal components before proceeding. Manoeuvring this appliance is into the builders opening will require 2 people.

1c Check the operation of the Secondary and primary air slider to ensure it operates smoothly . Do not fit the appliance if the sliders are stuck.

Appliance

It is recommended that the appliance is secured into the hearth, providing secure positioning for the stove. There are 4 holes in the base of the outer convection box to be able to secure the base of it using masonry anchor bolts.

Load bearing base

Ensure that the bottom of the convection box is installed on a load bearing with the strength to support the weight of the insert and the chimney. The insert can be loaded maximum 100 kg of chimney. The load bearing must not prevent the convection air ventilate the area between the insert and recess.

Hearth plate

Due to the risk of falling embers, a flammable floor must be protected by a hearth plate. It must extend 300 mm in front of the stove and 100 mm on each side of the stove, or have a 200 mm extension on each side of the opening. The hearth plate can consist of natural stone, concrete, metal plate or glass, consult the Building regulations.

Fixing to the hearth

2a It is recommended that this appliance is fixed to the hearth. This must be done before connecting the flue.

2b Slide the appliance into the opening taking care not to damage the hearth. Check that the fit is suitable and the appliance is in the correct position.

2c Mark drill holes on the hearth

2d Carefully remove the appliance from the opening.

2e Using a masonry bit, drill corresponding holes in the hearth and fit the masonry anchor bolts. (Not supplied)

2f The appliance is now ready to be secured to the hearth after the flue system has been connected.

Connecting the existing flue

4a The flue must be installed in accordance with the manufacturers instructions.

4b If the appliance is installed on an unlined, masonry flue, not recommended: — Fit a non-combustible closure plate to locate the first section of single wall flue pipe from the appliance to the old system. — Making the connection as with a flue liner system.

4c Do not connect the stove or flue system into large voids that could exist in older chimney systems. If this is the case consider using a flue lining system or closure plate to improve the operation of the appliance. Lining a large void around the stove with an insulating material, i.e. rockwool, is recommended. Before lifting the appliance into position on the hearth connect the Flue Liner/Pipe to the Flue Collar

Connection to Flue Liner/Pipe

Fit flue collar to flue liner /connecting pipe prior to putting stove into position

5a Slide the appliance back into the opening taking care not to damage the hearth. Check that the fit is suitable and the appliance is in the correct position.

5b Lower the flue collar into position above the appliance.

5c Secure the flue collar in place by fixing it to the Flue Flange with the bolts, nuts and washers provided,

5d The appliance can now be secured to the hearth using 1 x 6mm x 100mm (minimum) countersunk screws.

5e Finish the installation.

All open flued appliances can be affected by temporary atmospheric conditions which may allow fumes to enter the house.

Building regulations require that whenever a new or replacement fixed solid fuel or wood/biomass appliance is installed in a dwelling a carbon monoxide alarm must be fitted in the same room as the appliance.

Further guidance on the installation of the carbon monoxide alarm is available in the latest edition of BS EN50292 and from the alarm manufacturer's instructions.

Westfire recommend the unit is permanently fixed in accordance with the manufacturer's installation instructions or with the guidance contained in Approved Document J where no other information is available. Provision of an alarm must not be considered a substitute for either installing the appliance correctly or ensuring regular servicing and maintenance of the appliance and chimney system .

Recessing the insert

When recessing the insert, adjacent walls that are not classed as fire walls or are considered unsuitable for heat loads must be protected by non-combustible material according to the specification below.

All joints on the non-combustible material must be sealed using the manufacture's recommended method. The area between the insert and the recess must be ventilated according to the specification/dimension.

When top connecting a steel flue please refer to the relevant manufacturer's installation instructions. Observe the safety distances to combustible material that steel flues require. Heat radiation from the glass door is strong and is why combustible material must not be placed closer than 1m in front of the front of the stove. When recessing, building material must not be in direct contact with the insert due to the thermal expansion of the insert.

Material requirements

The building material must not be combustible.

The thermal conductivity coefficient λ may be a maximum of 0.14 W/mK.

The thickness of the building material must always be at least 100 mm.

In cases where the building material's insulation properties are given as a U-Value, this must be a maximum of 1.4 W/ m²K.

List of suitable materials:

Aerated concrete:

$\lambda = 0.12-0.14$

Vermiculite:

$\lambda = 0.12-0.14$

Calcium silicate:

$\lambda = 0.9$

Convection air

The convection air ventilates the surround, cools the insert and transports the hot air out into the room. The total sum of the effective cross section area up and down must not be less than the stated values. The air intake must be positioned somewhere between the floor and the bottom of the insert, up to or on the sides of the recess. The vent must be positioned above the insert's highest point, up to or to the sides of the recess. A closure plate should be fitted above the top vents. Observe the minimum distance up to the ceiling.

Convection air in: 200 cm² Convection air out: 200 cm²

Note that building regulations apply regarding the area below and in front of the insert, see section "Hearth plate" on page 6.

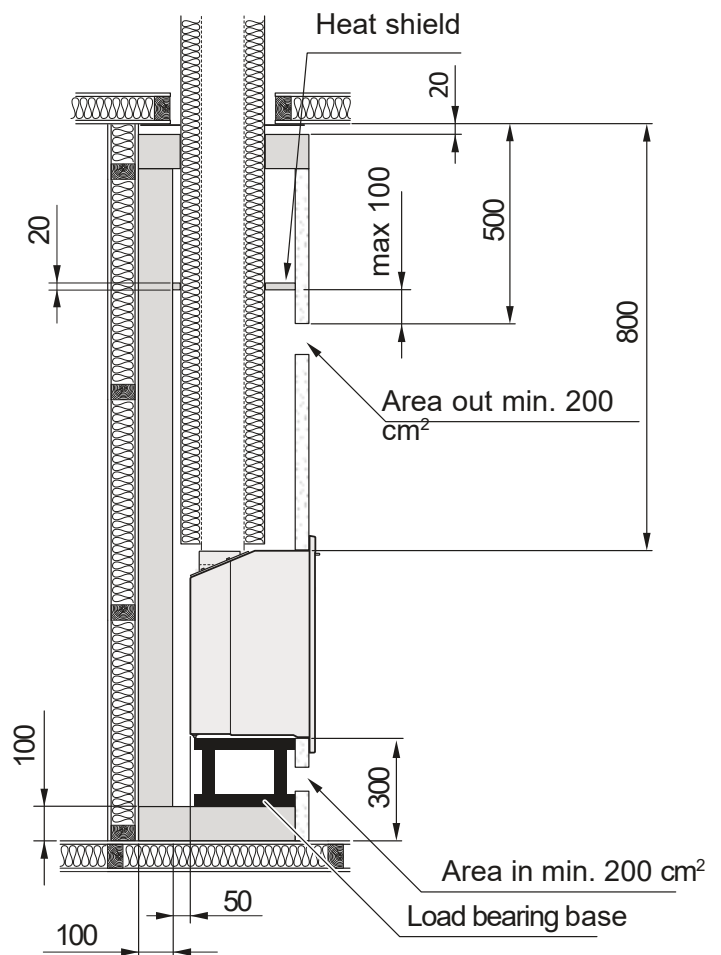
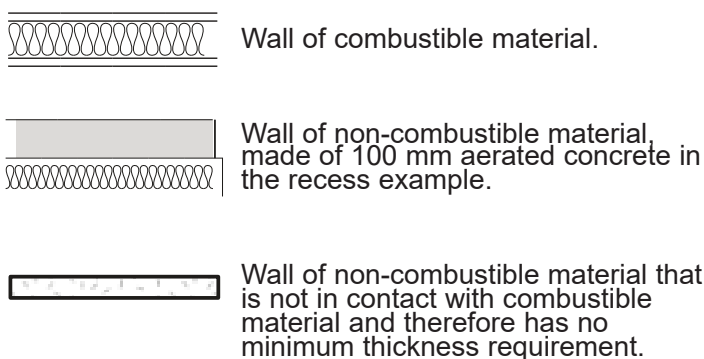

Recess example

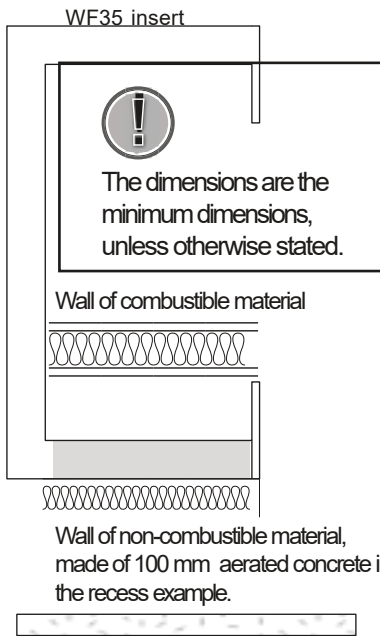

Wall of non-combustible material that is not in contact with combustible material and therefore has no minimum thickness requirement.

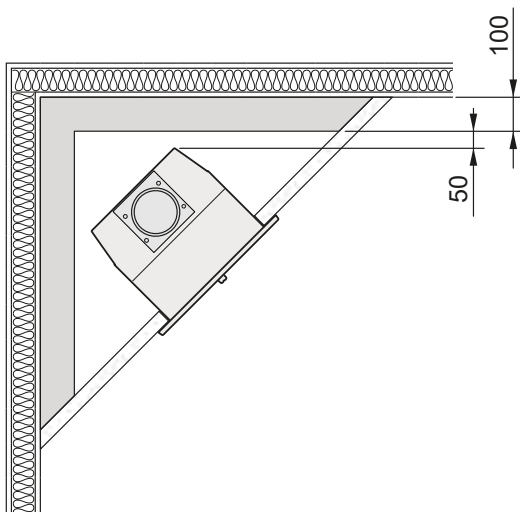
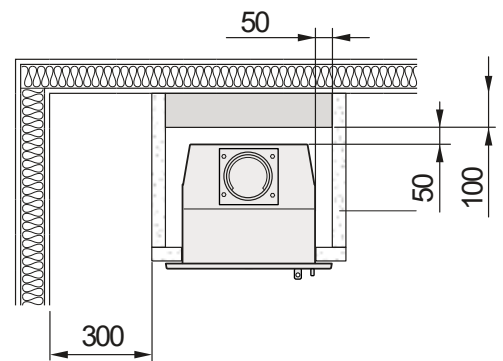
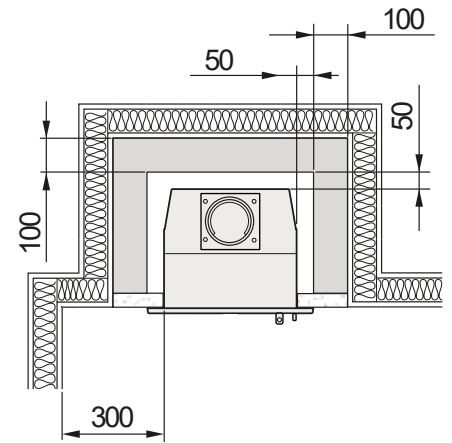
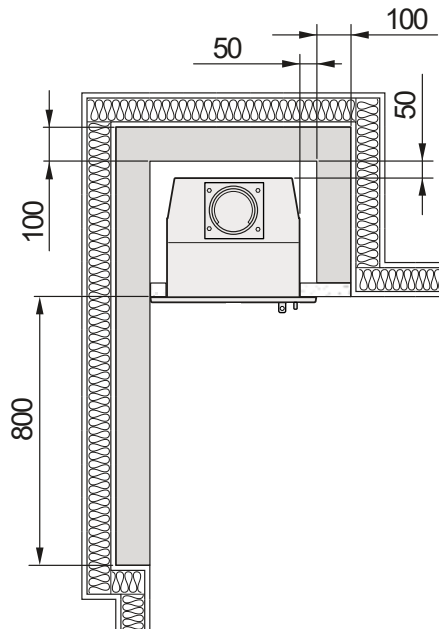

If a secondary lintel is to be fitted with only a single thickness of brick to be used as the closure, the inner face of the bricks should be faced with insulation material e.g Rockwool, to reduce the temperature of the wall face. If not using a fresh air kit then an 50mm gap should be left to the rear.

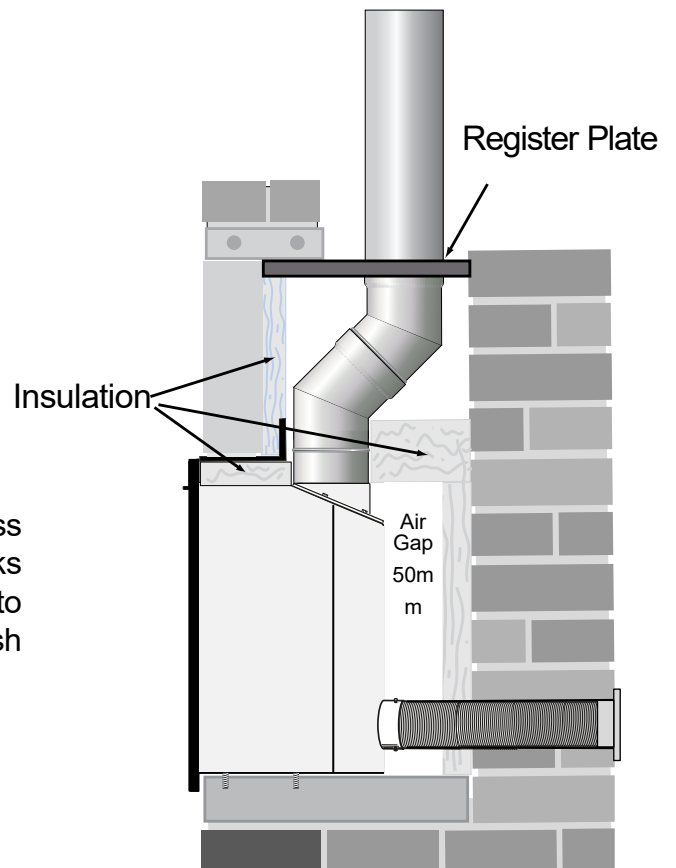

Housing Construction, without an Existing Chimney Breast

If the property has no existing chimney or chimney breast the first consideration will be the positioning of the flue. Taking the flue to the roof internally through the property will involve complying with many regulations and even an external flue may be subject to planning regulations. Because there will be no existing structural hearth, this will need to be constructed following the strict Building Regulation requirements. For these reasons we cannot recommend that anyone without the necessary experience constructs the housing and flue system for a WF35 insert stove.

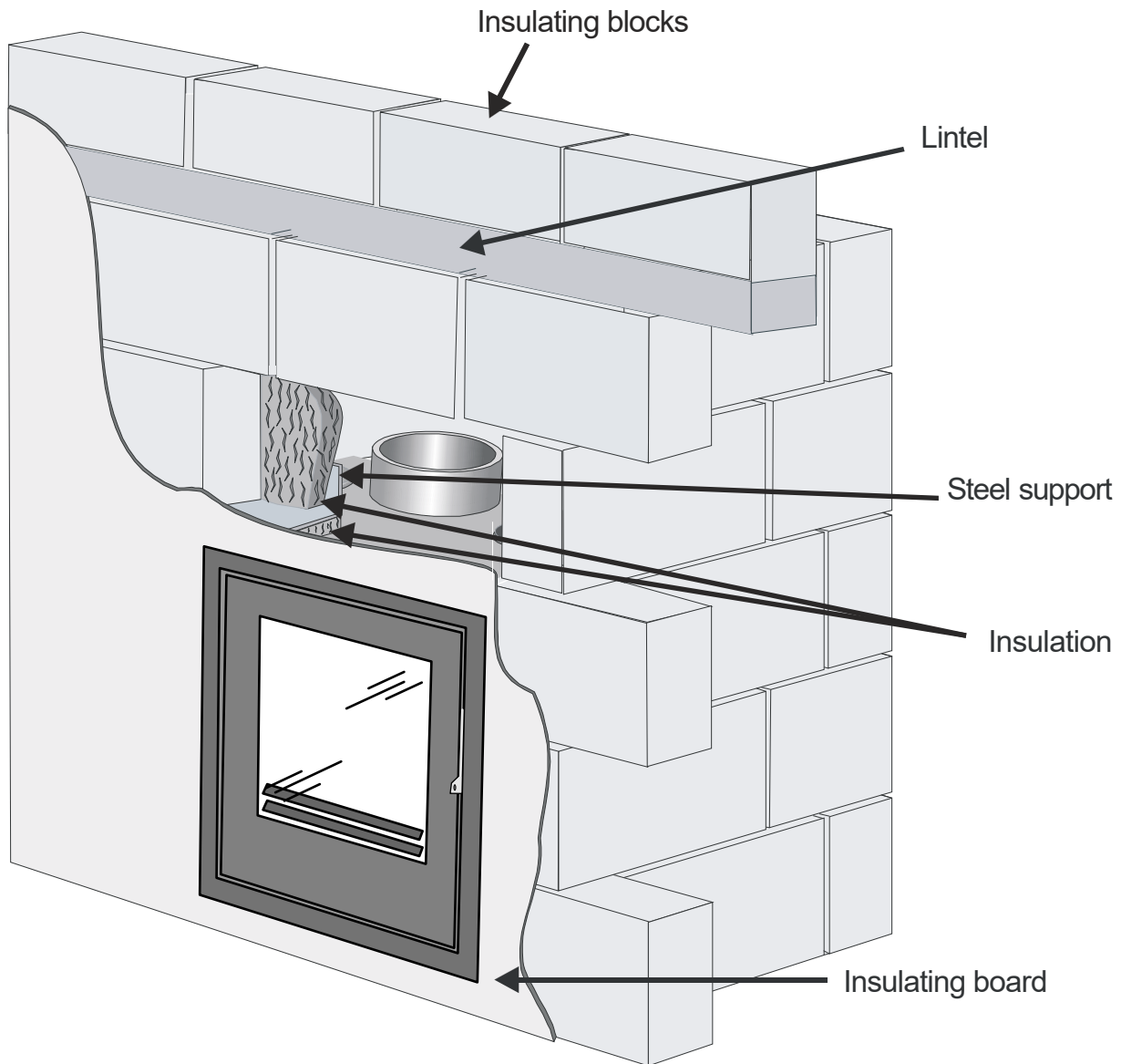

Because the temperatures reached by the stove's top and side panels may reach over three hundred degrees Celsius all materials used for constructing the housing must be both non-combustible, stable at high temperatures and insulate any part of the building which may be affected by heat. It should be borne in mind that insulating materials only limit the rate of heat transference from the heated surface to the unheated surface and if the dispersal of heat from the unheated surface is less than the rate of heat transference the entire body of insulating material will reach an almost uniform temperature.

The insulating properties of many modern houses are extremely high and many external walls are now constructed with an inner skin of plasterboard, supported on a wooden frame which is thermally insulated from the outer skin of brick. Having such a low thermal conductivity makes it impossible to use the outer wall as the back of the stove's housing unless a means of ensuring that non of the heat from the stove is transferred to the house wall. Whilst this may sound daunting the reward will be a vast increase in heating efficiency.

One solution to the problem is to leave a space between the stove's housing back and the wall and provide ventilation to give an air flow between the two. The housing should be constructed with insulating blocks and faced with brick or an insulating board and for extra protection the housing can be lined with rockwool but these should be supported so as not to touch the stove body.

The provision of insulation and air flow will also apply to the heat reaching the ceiling of the room and this will need extra care if the chimney is to be routed internally through the property.

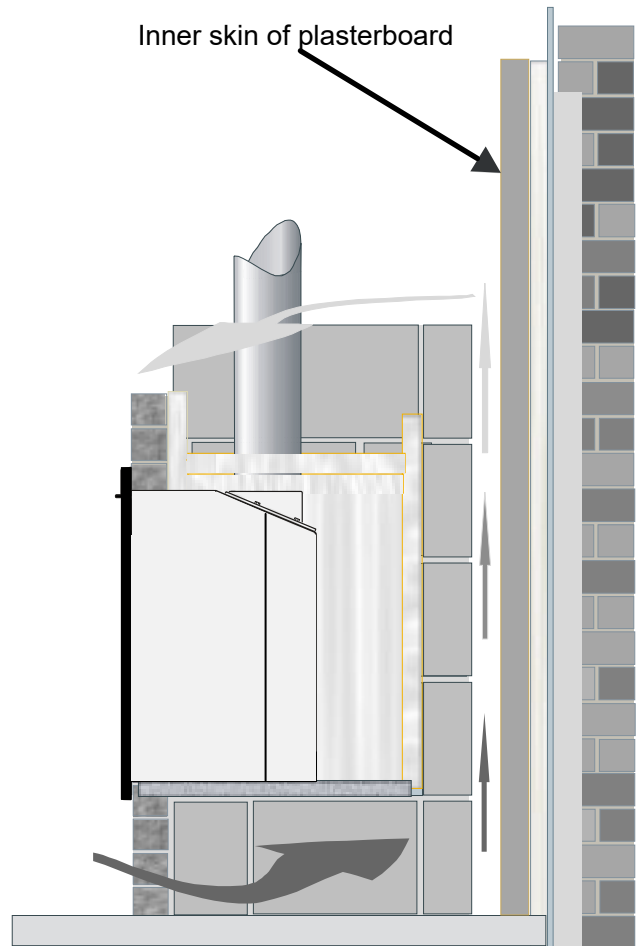

Installation utilising warm air ducts to the side of the chimney breast

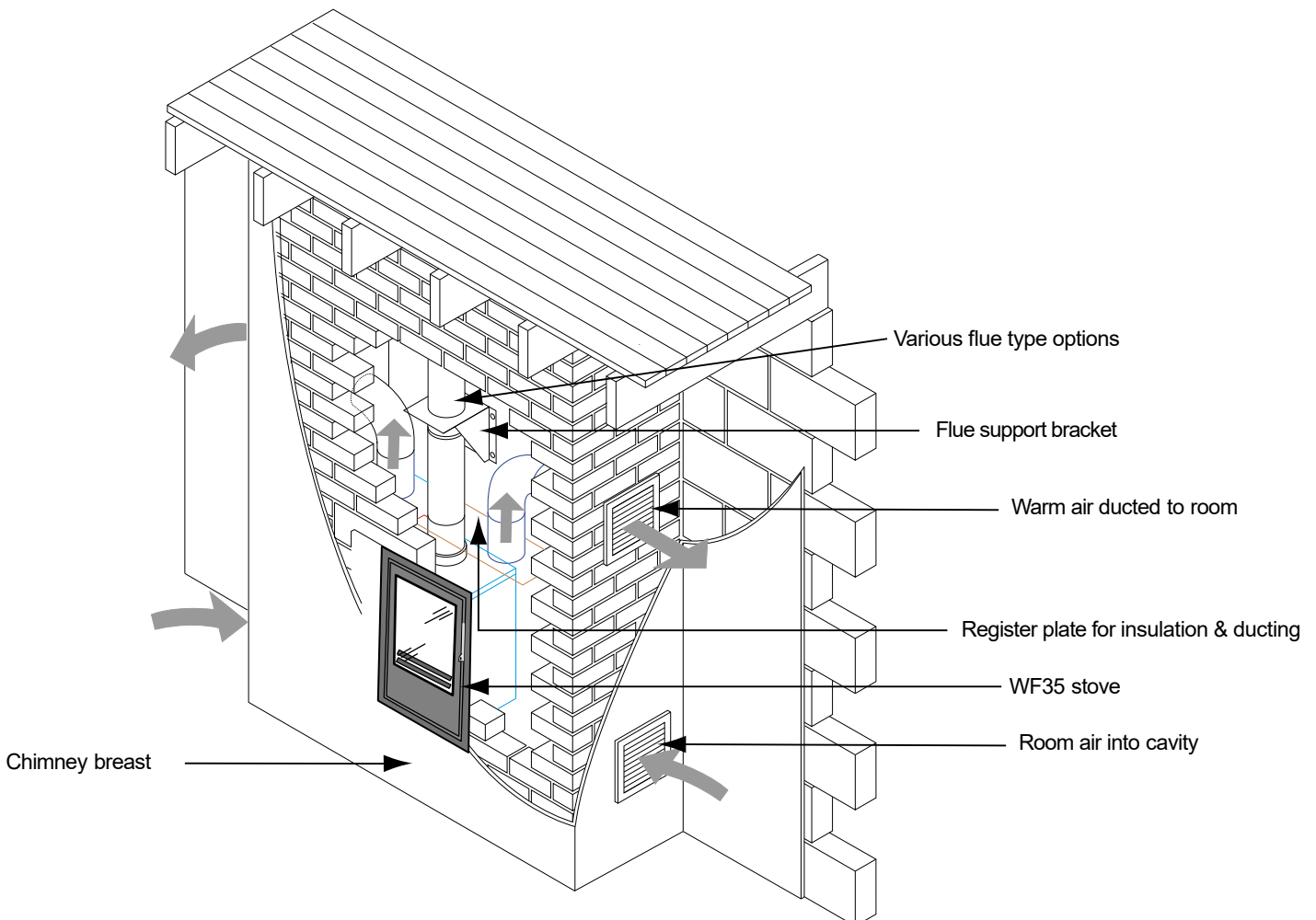

Remove all the internal components from the stove

Prior to installing the outer convector box and stove carefully remove all the components from the stove and put somewhere where they will not become damaged. Follow the instructions on page 28 of this manual.

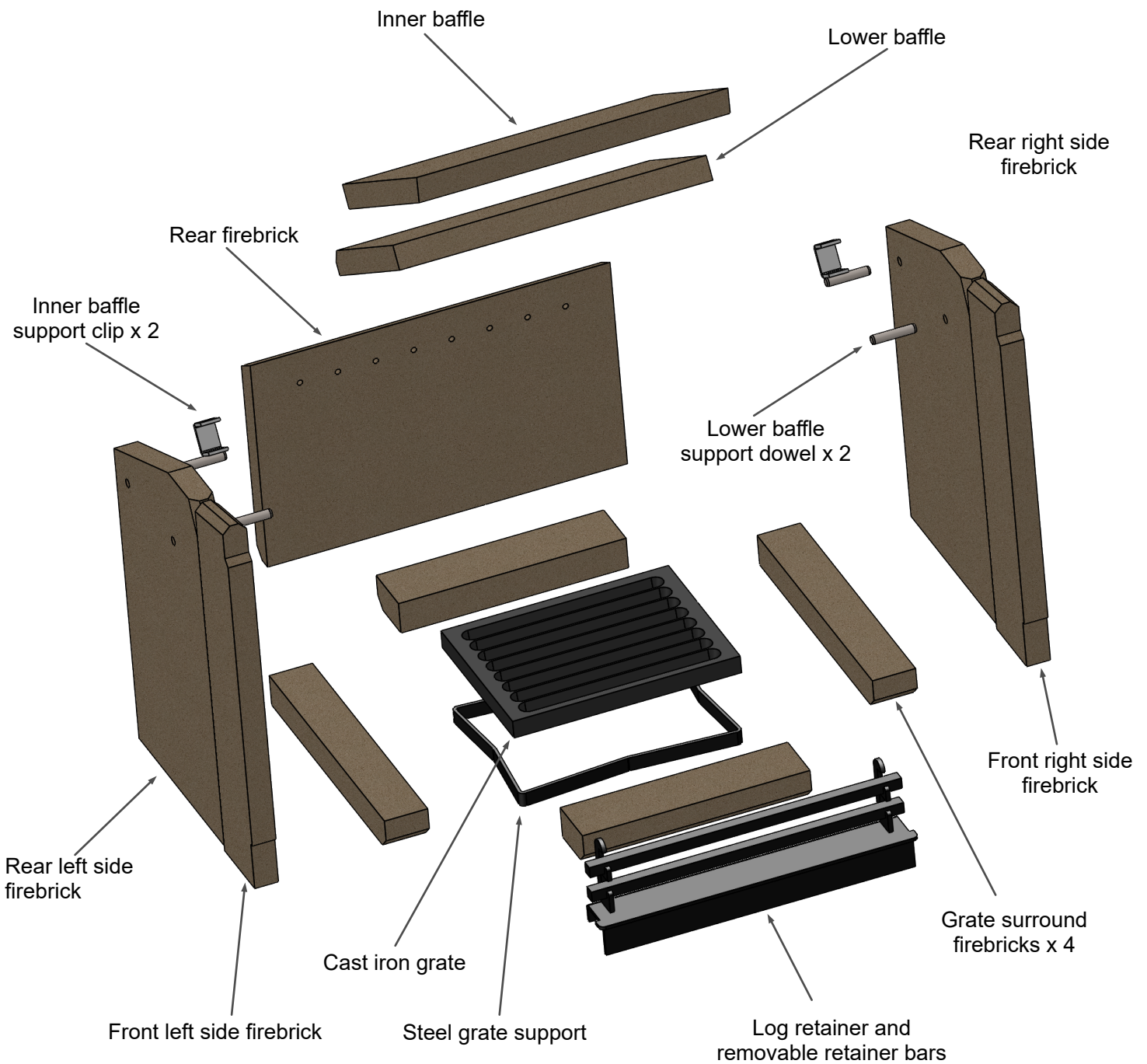

IMPORTANT:

Please take great care when handling the vermiculite firebricks and place them somewhere so they will not get damaged.

Flue collar direction

Vertical connection

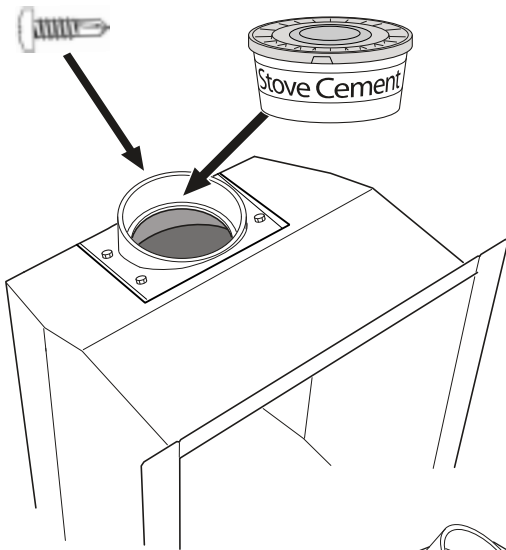

45° connection

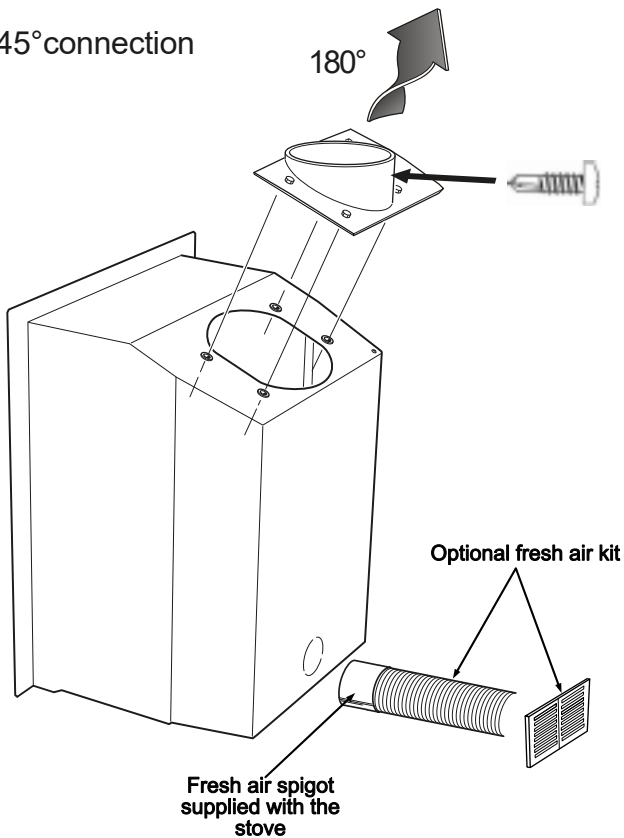

The flue direction can be changed from the vertical to a 45° connection by lifting out the flue collar and fixing plate and turning it through 180°.

Take the flue adapter off the stove.



The flue pipe can then be inserted into the collar and sealed with fire cement. The flue collar will need to be drilled so that self tapping screws can be used to provide a physical retention to the flue pipe.

This is now ready for when the stove is fitted into place, where it can be pulled down into position from within the stove and secured with the 4 x M6 nuts.

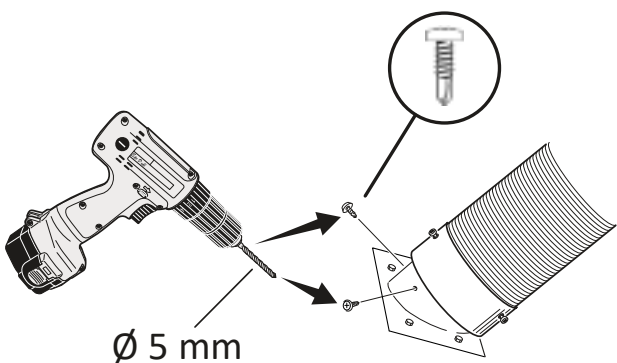

Securing the outer convector box

Fit the outer convector box into the opening and mark the position of the 2 holes on the base below. Remove the outer convector box and drill the holes into the base below.

Using masonry anchor bolts secure the box to the base.

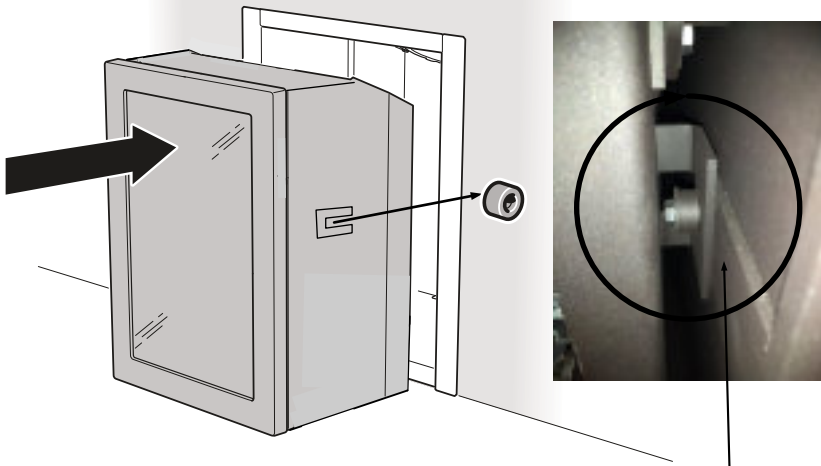
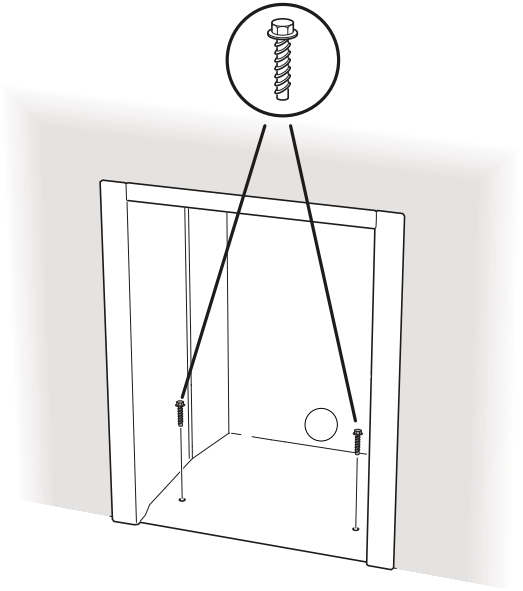

Securing the stove

Slide the stove into the outer convector box ensuring the 2 location and securing brackets align with the securing bolts. Tighten the bolts with a 10mm spanner.

Reach through the stoves flue outlet and pull down the flue adapter into position and secure in place with the 4 x nuts.

Fitting the frame

The frame can now be secured to the body with the 3 screws, 2 at the bottom and 1 at the top. The locating brackets on the side of the frame tightened with the 2 x 10mm bolts holding the body in place.

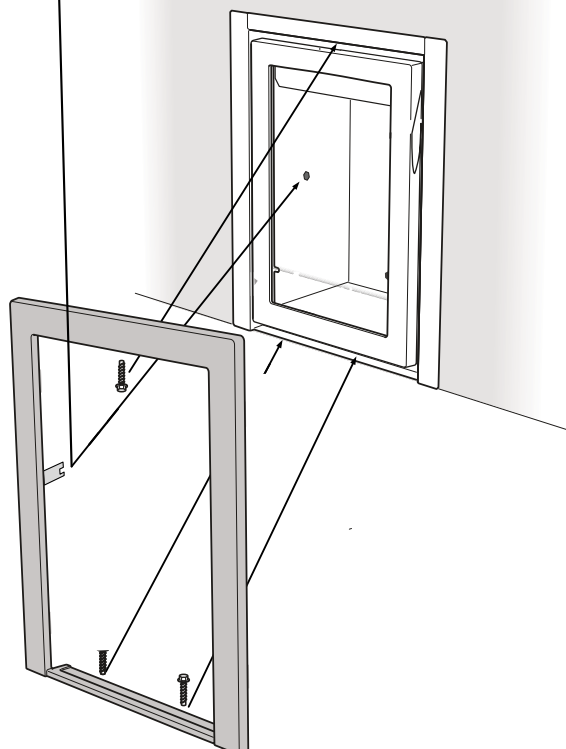

HEARTH

The hearth should be able to accommodate the weight of the stove and its chimney if the chimney is not independently supported. The WF35 inset stove has been tested and are suitable to be installed on a 12 mm non combustible plate such as 12 mm glass plates . Installation of all hearths should comply in size and construction so that it is in accordance with the provisions of the current Building Regulations Approved Document J.

The clearance distances to combustible material beneath, surrounding or on the hearth and walls adjacent to the hearth should comply with the guidance on the separation of combustible material given in Building Regulations Approved Document J and also in these stove instructions.

If the stove is to be installed on a wooden floor, it must be covered with a non-combustible material at least 12 mm thick, in accordance with Building Regulations Approved Document J, to a distance of 30 cm in front of the stove and 15 cm to each side measuring from the door of the combustion chamber.

COMBUSTION AIR

In order for the stove to perform efficiently and safely there should be an adequate air supply into the room in which the stove is installed to provide combustion air. This is particularly necessary if the room is double-glazed or a flue draught stabiliser is operating in the same room as the appliance. The provision of air supply to the stove must be in accordance with current Building Regulations Approved Document J. An opening window is not appropriate for this purpose. Air inlets must be positioned in such a way that they cannot be blocked. An air inlet may be a vent (the vent must be open and the capacity for the vent sufficient when the stove is lit) .

WF35 models take all combustion air from a single 80mm port at the rear of the stove, with the door closed the air port supplies all combustion air for the appliance. This can be connected to the outside via a 80mm pipe so the appliance does not draw air from the room. However Westfire stoves still recommends the use of an air brick as laid out in Document J for when the stove is being reloaded.

COMBUSTION CHAMBERS

Westfire Stoves are fitted internally with vermiculite heat deflection panels and baffles, these panels are designed to ensure the maximum efficiency and are an integral part of the clean burn process of the stove. These baffles should not be removed other than for cleaning the stove. Any defective panels should be replaced, small hairline cracks do need replacement and can develop during long term use. When refuelling your stove place wood fuel into the chamber, impact from logs can cause the heat deflection panel to crack.

Connection to chimney

Westfire 35 is built with a top flue outlet only, this can be altered from vertical to a 45 degrees connection by removing the top collar and rotating the collar 180 degrees,. Care should be taken to ensure an airtight fit when refitting collar and plate. This collar allows connection to either a masonry chimney or a prefabricated factory made insulated metal chimney.

COMMISSIONING AND HANDOVER

Ensure loose parts (brick and grates) are fitted in accordance with the instructions given in the instruction booklet. On completion of the installation allow a suitable period of time for any fire cement and mortar to dry out, a small fire may be lit to check that smoke and fumes are taken from the stove up the chimney and emitted safely into the atmosphere. Do not run at full output for at least 24 hours.

On completion of the installation and commissioning ensure that the operating instructions for the stove are left with the customer. Ensure to advise the customer on the correct use of the appliance with the fuels likely to be used in the stove and notify them to use only the recommended fuels for the stove. Advise the user what to do should smoke or fumes be emitted from the stove.

The customer should be warned to use a fireguard to BS 8423:2002 in the presence of children, aged and/or infirm persons.

OPERATING YOUR STOVE - WF35 INSERT

Suitable fuels

Your stove is tested to burn wood or registered smokeless coal. Wood briquettes can also be burnt but special account should be taken of fuel weight. For a full list of suitable fuels, check with the official solid fuels approvals body, HETAS or Solid Fuel Association. Do not overload stove as this can cause excessive heat and damage the stove (see table on page 6).

ALWAYS KEEP FUEL LOAD BELOW TERTIARY PORTS AT REAR OF STOVE. Only use fuels approved for use on heating stoves.

Do not burn liquid fuels, drift wood, finished wood, sawn wood, pallet wood, chipboard/plywood, varnished wood or plastic coated wood, wood treated with preservatives, or any house hold waste.

**DO NOT EXCEED SPECIFIED FUEL WEIGHTS.
DO NOT BURN HOUSE COAL. DO NOT BURN HOUSEHOLD WASTE,
THIS APPLIANCE IS NOT AN INCINERATOR.**

LIGHTING YOUR STOVE FOR THE FIRST TIME

Before lighting your stove for first time make sure you have read this manual fully and acquainted yourself with the controls of this appliance. (see page 19)

The heat-resistant paint on your stove will cure and harden the first time you light your appliance.

The curing process produces a good deal of smoke and odour, it is therefore important that the first time you light your stove the room should be well ventilated.

During the process it is important to open and close the stove door periodically (every 30mins) during the first couple of firings therefore preventing the door seal cord around the door from sticking and coming away from the door. Once the heat-resistant paint has hardened the smell will disappear.

Your stove is NOT designed to be used with the door open, the stove door must be kept closed except when lighting the stove, adding firewood or removing ash in order to prevent flue gases from escaping.

Use of Fire lighters

Quality Firelighters should be used when lighting your stove. (Never use mentholated spirit, petrol or other flammable liquids).

Lighting your stove with firelighters will be more reliable and easier than using paper. Lighting your fire with paper results in excess smoke, more ash and possible blackening of glass.

OPERATING YOUR STOVE - WESTFIRE 35- AIR CONTROLLER

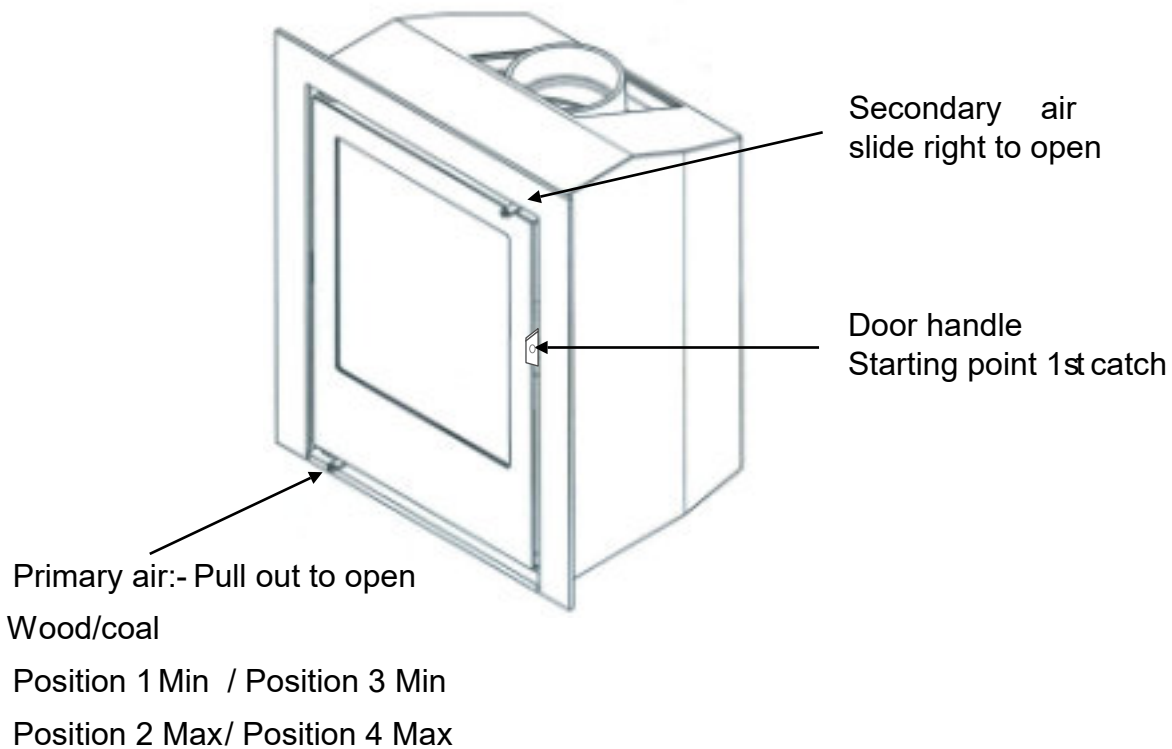

Primary air control settings

When burning wood use position 1 to position 2

When burning wood use primary air control from position 1 (fully pushed in) to position 2 (when controls stops) . Do not move beyond this position for wood burning.

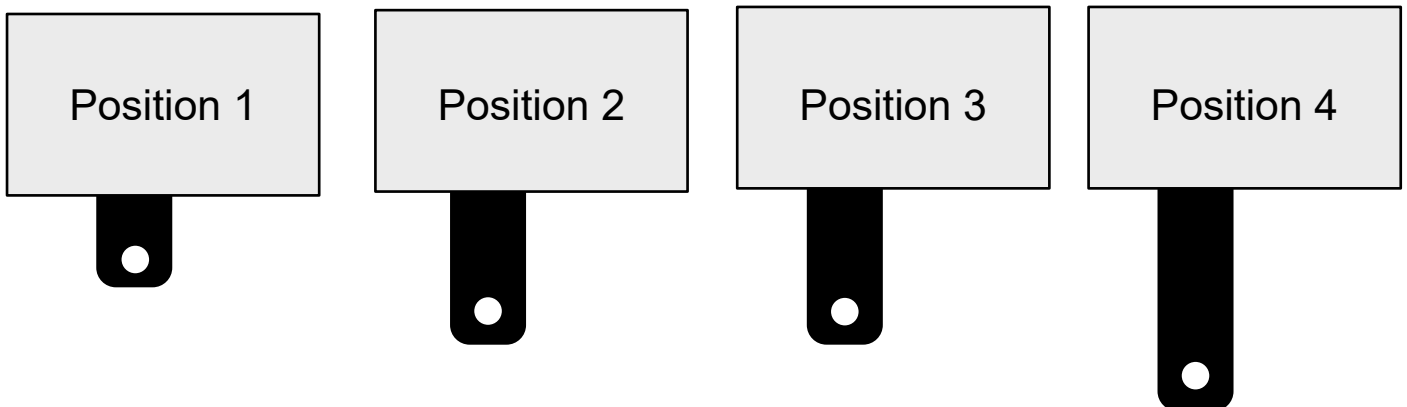

When burning coal use position 3 to position 4

When burning coal the primary air control drops to position 3 (midpoint location) operate and regulate your stove between position 3 and 4 (fully pulled out).

HOW TO LIGHT YOUR WOODBURNING STOVE

Note: If the chimney is externally fitted or the stove has been installed on a larger diameter clay chimney liner then on cold days it may be necessary to warm the flue using firelighters prior to lighting with wood.

1. Place two small dry split logs ($\frac{1}{4}$ split) on the fire bed. Kindling stacked as in the picture allows combustion air to flow freely and will aid ignition. On top of the kindling two or more non toxic firelighters.



2. Fully open the secondary air control above the stove door on right hand side. Fully open primary air control at base left of stove. The WF35 inserts air controls are now fully open.

3) Light the firelighters and push door to closed position, latch in 1st position so the door is open 2 mm. (see picture) This provides additional combustion air for start up and reduces condensation on the door glass.

NEVER leave the stove unattended when the door is ajar in latch position 1.

4. Once the flames from the logs are fully established, this can take up to 10 min's. The door can now be fully closed (position 2). Once fire is burning brightly again close the primary air control.

This will close off the primary air to the stove. If the stove begins to falter after the primary is closed, open primary control again and leave until fire has established, then close.

6. The fire should now be fully established and burning brightly. At this stage close secondary air control by 50%, this is the operational setting. For the stove to burn cleanly and efficiently plenty of secondary air is needed, do not be tempted to shut the fire down too early as this may cause smoke. At nominal heat output, expect to refuel your stove once an hour. Check load weights for your model on the table on page 6. Use the glove when operating air controls and door.



The stove will get very hot during use and due care must therefore be exercised.
Please use the glove when operating air controls, door and ashpan.
Never let children "help" with the stove in any way, even when the stove is cold.

RE-FUELLING WHEN BURNING WOOD

To re-fuel your stove in the cleanest way only refuel your stove when flames have died down and you have glowing embers.

Before refuelling, open secondary air control fully, open primary air control fully. Open door, add two pieces of split wood measuring approximately 30cm with a combined weight of 1.2kg. Close the door and leave the primary and secondary air controls open until fire is re-established with flames. Close primary air control and slide secondary air control to the operational position (50% open).

Experience will determine the settings that produce best results, this may vary with the type and quality of the wood being used in the stove.

BURNING WOOD IN A SMOKE CONTROL AREA

You must purchase a smoke control 'SE' version of the Westfire stove which is modified slightly to comply with regulations. Any change to this modification will invalidate the stoves compliance for smoke control areas.

The Clean Air Act 1993 and Smoke Control Areas

Under the Clean Air Act local authorities may declare the whole or part of the district of the authority to be a smoke control area. It is an offence to emit smoke from a chimney of a building, from a furnace or from any fixed boiler if located in a designated smoke control area. It is also an offence to acquire an "unauthorised fuel" for use within a smoke control area unless it is used in an "exempt" appliance ("exempted" from the controls which generally apply in the smoke control area).

In England appliances are exempted by publication on a list by the Secretary of State in accordance with changes made to sections 20 and 21 of the Clean Air Act 1993 by section 15 of the Deregulation Act 2015. Similarly in Scotland appliances are exempted by publication on a list by Scottish Ministers under section 50 of the Regulatory Reform (Scotland) Act 2014.

In Wales and Northern Ireland these are authorised by regulations made by Welsh Ministers and by the Department of the Environment respectively.

Further information on the requirements of the Clean Air Act can be found here:

<https://www.gov.uk/smoke-control-area-rules>

Your local authority is responsible for implementing the Clean Air Act 1993 including designation and supervision of smoke control areas and you can contact them for details of Clean Air Act requirements. The models have been recommended as suitable for use in smoke control areas when burning wood logs. The appliances can also burn Authorised fuels in smoke control areas (<http://smokecontrol.defra.gov.uk/fuels.php>).

SE appliances include a modified air control to prevent closure of the secondary air control beyond 25% open, alterations should not be attempted.

Westfire smoke control stoves should not be burnt with the door left open.

The refuelling procedure : - allow the newly charged fuel to burn with the secondary air control set at maximum for up 3 to 4 minutes. After this period, with flames from the logs fully established, close the secondary air supply to the low output setting. When operating at high output (secondary air set fully open) the new refuel charge does not require any boost air to establish combustion.

Refuelling on to a low fire bed

If there is insufficient burning material in the firebed to light a new fuel charge, excessive smoke emission can occur. Refuelling must be carried out onto a sufficient quantity of glowing embers and ash that the new fuel charge will ignite in a reasonable period. If there are too few embers in the fire bed, add suitable kindling to prevent excessive smoke.

Fuel Overloading

The maximum amount of fuel specified in this manual should not be exceeded, overloading can cause excess smoke.

Air controls & doors left open

Operation with the air controls fully open can cause excess smoke. The appliance must not be operated with air controls, or door left open except as directed in the instructions.

LIGHTING THE STOVE - SOLID FUELS

Note: on cold days it maybe necessary to warm the flue using two firelighters.

1. Place a few smaller pieces of dry wood (kindling) in the stove on top of the nontoxic firelighters, place one or two small dry split logs and small quantity of Smokeless coal.
- 2 Fully open the secondary air control above the stove door on right hand side. Fully open primary air control at base left of stove. The WF35 insert stove air controls are now fully open.
3. Light the firelighters and push door to closed position and close handle to 1st position; this will allow a small gap in the door for more air to be supplied to stove during ignition period.
4. When the flames are established and the fire is burning brightly load 1.1 kg of smokeless coal and close door latch to position 2 fully closed. Once the fire is burning maintain the secondary air control 100%.
- 5 Now the fully established fire bed is burning brightly. Maintain primary air control at 100%, this is the operational setting. For the stove to burn cleanly and efficiently primary air is needed, do not be tempted to shut the fire down too early as this may cause smoke. At nominal heat output, expect to refuel your stove once every two hours.

Re-fueling solid fuel

To re-fuel your stove. Only refuel your stove when flames have died down and you have glowing embers. Before refuelling riddle your stove with a poker (NOT INCLUDED) , open secondary air control fully, open primary air control fully . Open door and re load 1.1 kg of smokeless coal. Close the door and leave the primary and secondary air controls open until fire is re-established. Maintain secondary air control at 100% and maintain primary air control to it operational position (100% open). In the event of a chimney fire: Close the air controls and the stove door, and call 999 or your local fire brigade.

If your stove is overheating close all air sliders and door, leave until the stove has returned to normal temperature. The stove is only suitable for intermittent use only: do not run overnight or for long periods unattended.

Experience will determine the settings that produce best results. The stove will get very hot during use and due care must therefore be exercised.

Please use the glove and operating tool supplied when operating air controls and door.

SOLID SMOKELESS FUELS- Westfire 35 models are suitable for use with good quality smokeless fuels and have been fully tested to the relevant European standard. Only use registered smokeless fuels on this stove. Take special note of load quantities in front of this book.(page 6)

HOUSE COAL AND PETROLEUM COKE ARE NOT SUITABLE FOR USE ON THIS STOVE; ITS USE WILL INVALIDATE THE GUARANTEE.

INCOMPLETE COMBUSTION

If the air controls on your stove are closed too much incomplete combustion may lead to a build-up of hard, shiny soot on

the inside of your stove and glass. To prevent sooting of the chamber and glass introduce:-

- 1) more secondary air,
- 2) check that your fuel is suitable and dry.
- 3) that you have sufficient draw in your chimney.

It is important to check the draft conditions before lighting your stove. This may be done, for instance, by crumpling a piece of newspaper, placing it in the combustion chamber and lighting it. The draft conditions are good if the smoke is drawn away through the chimney.

OVERNIGHT BURNING

Westfire stoves do not recommend burning registered smokeless coal in a slumbering position, Westfire stoves are designed to burn wood and quality registered smokeless fuels. Wood burns more efficiently and cleanly if it is burnt hotter. Westfire stoves do not recommend that their stoves are burnt overnight for this reason. As a night time regime we recommend that the fire is loaded when hot and burnt for five minutes with the secondary air control fully open until the new wood has taken and is burning, then close the secondary air valve to its operational position. On returning to the stove in the morning the fire will have burnt out, reload with some paper or firelighter and some kindling and open both air sliders fully to relight quickly. Beware as the ash bed will have hot embers.

PERMANENT AIR VENT

The stove requires a permanent air vent to the room. This is to provide adequate air supply in order for the stove to operate safely and efficiently. In accordance with current Building Regulations the installer may have fitted a permanent air supply vent into the room in which the stove is installed to provide combustion air. This air vent should not under any circumstances be shut off or sealed.

WARNING NOTE

Properly installed, operated and maintained this stove will not emit fumes into the dwelling. Occasional fumes from de-ashing and re-fuelling may occur. However, persistent fume emission is potentially dangerous and must not be tolerated. If fume emission does persist, then the following immediate action should be taken:-

- (a) Open doors and windows to ventilate the room and then leave the premises.
- (b) Let the fire go out.
- (c) Check for flue or chimney blockage and clean if required
- (d) Do not attempt to relight the fire until the cause of the fume emission has been identified and corrected. If necessary seek expert advice.

The most common cause of fume emission is flue way or chimney blockage. For your own safety these must be kept clean at all times.

CO Alarm

Your installer should have fitted a CO alarm in the same room as the appliance. If the alarm sounds unexpectedly, follow the instructions given under "Warning Note" above.

Aerosols

Aerosols are flammable and therefore dangerous to use around a lit stove. Do not use aerosols sprays near your lit stove. The use of any aerosol is dangerous and care must be taken in handling aerosols.

TROUBLE SHOOTING

1. Fire Will Not Burn - check
 - a) the air inlet is not obstructed in any way,
 - b) that chimney and flue ways are clear,
 - c) that a suitable fuel is being used,
 - d) that there is an adequate air supply into the room,
 - e) that an extractor fan is not fitted in the same room as the fire.

2. Fire Blazing Out Of Control - check
 - a) the doors are tightly closed,
 - b) the air controls are turned down to the minimum setting,
 - c) the flue damper is closed (if fitted),
 - d) a suitable fuel is being used,
 - e) the door seals are in good condition.
 - F) the chimney draft may be too strong
 - G) check ash pan seal and
 - H) check for ash below ash pan causing pan to seat incorrectly and clean out.

- 3) Soot forms on the window
 - a) The firewood may be too wet
 - b) the intake of secondary air may be insufficient
 - c) fire not hot enough

- 4) The stove fails to heat fully
 - a) The firewood may be too wet
 - b) the intake of secondary air may be insufficient

- 5) Smoke or odour
 - a) weak chimney draft
 - b) check for blockages in the flue pipe/chimney
 - c) check the height of the chimney relative to the surroundings

- 6) Soot in the chimney
 - a) The firewood may be too wet
 - b) intake of secondary air may be insufficient

MAINTENANCE

Annual service

Westfire stoves recommends that your model needs to have the ash removed from the stove at regular intervals (weekly if used daily). Allowing the ash pan to over flow can impede the function of the stove and can cause possible damage to the stove grate and ash pan. To remove ash pan use ash pan tool to hook under slot front of ash pan drawer. Lift and pull out of firebox chamber. Take care to support ash pan during movement, always wear a heat resistant glove. Make sure the stove is completely cold before cleaning out ash (embers can remain hot for over 24 hours).

Ash must be stored in a non-combustible container and must not be mixed with other combustible waste.

Prolonged non use (summer)

If the stove is to be left unused for a prolonged period of time (e.g. over the summer) then it should be given a thorough clean to remove ash and unburned fuel residues. To enable a good flow of air through the appliance to reduce condensation and subsequent damage, leave the air controls fully open.

It is important that the flue connection, any appliance baffles or throat plates and the chimney are swept prior to lighting up after a prolonged shutdown period.

Spare parts & unauthorised alterations

Only the manufacturer's own components, or replacement parts recommended and approved by Westfire stoves, shall be used for appliance servicing and repair. Any unauthorised alterations will invalidate the stove warranty and compliance with EN13240.

SWEEPING YOUR CHIMNEY & CHIMNEY FIRES

Ensure that your appliance, flue ways and chimney are swept regularly. This can be incorporated in the service regime of your appliance. Regular sweeping is essential and means at least once a year for smokeless fuels and a minimum of twice a year for wood . If a throat plate is incorporated, it is essential that the throat plate is removed and cleaned above, all ash and debris should be removed. Ensure adequate access to cleaning doors where it is not possible to sweep the chimney through the appliance.

Where a chimney has served an open fire installation previously it is possible that the higher flue gas temperature from a closed appliance may loosen deposits that were previously firmly adhered, with the consequent risk of flue blockage. It is therefore recommended that the chimney be swept a second time within a month of regular use after installation of the stove.

Chimney Fires

If the chimney is thoroughly and regularly swept, chimney fires should not occur. However, if a chimney fire does occur turn the air control setting to the minimum, and tightly close the doors of the stove. This should cause the chimney fire to go out in which case the control should be kept at the minimum setting until the fire in the stove has gone out. The chimney and flue ways should then be cleaned. If the chimney fire does not go out when the above action is taken then the fire brigade should be called immediately.

After a chimney fire the chimney should be carefully examined for any damage. Expert advice should be sought if necessary.

STOVE PARTS, COMBUSTION CHAMBER, ASSEMBLY

This section shows the parts contained in your stove, each stove has over 80 spare-parts and, each part is detailed. When new parts are required the section will allow spares to be recognised and ordered. As a further source of reference please visit www.eurostove.co.uk for latest spare-part information.

LOOSE PARTS

Always use the operating tools provided when handling parts likely to be hot when the stove is in use. Your stove has the following parts in the stove.

1. Cast Iron grate
2. Tool
3. Ashpan
4. Stove Glove
5. Instruction manual & warranty card
6. Vermiculite brick linings (these are integral to the stoves performance-Do not throw away)
7. Fresh air spigot
8. Moisture absorbency bag

STOVE PARTS, COMBUSTION CHAMBER

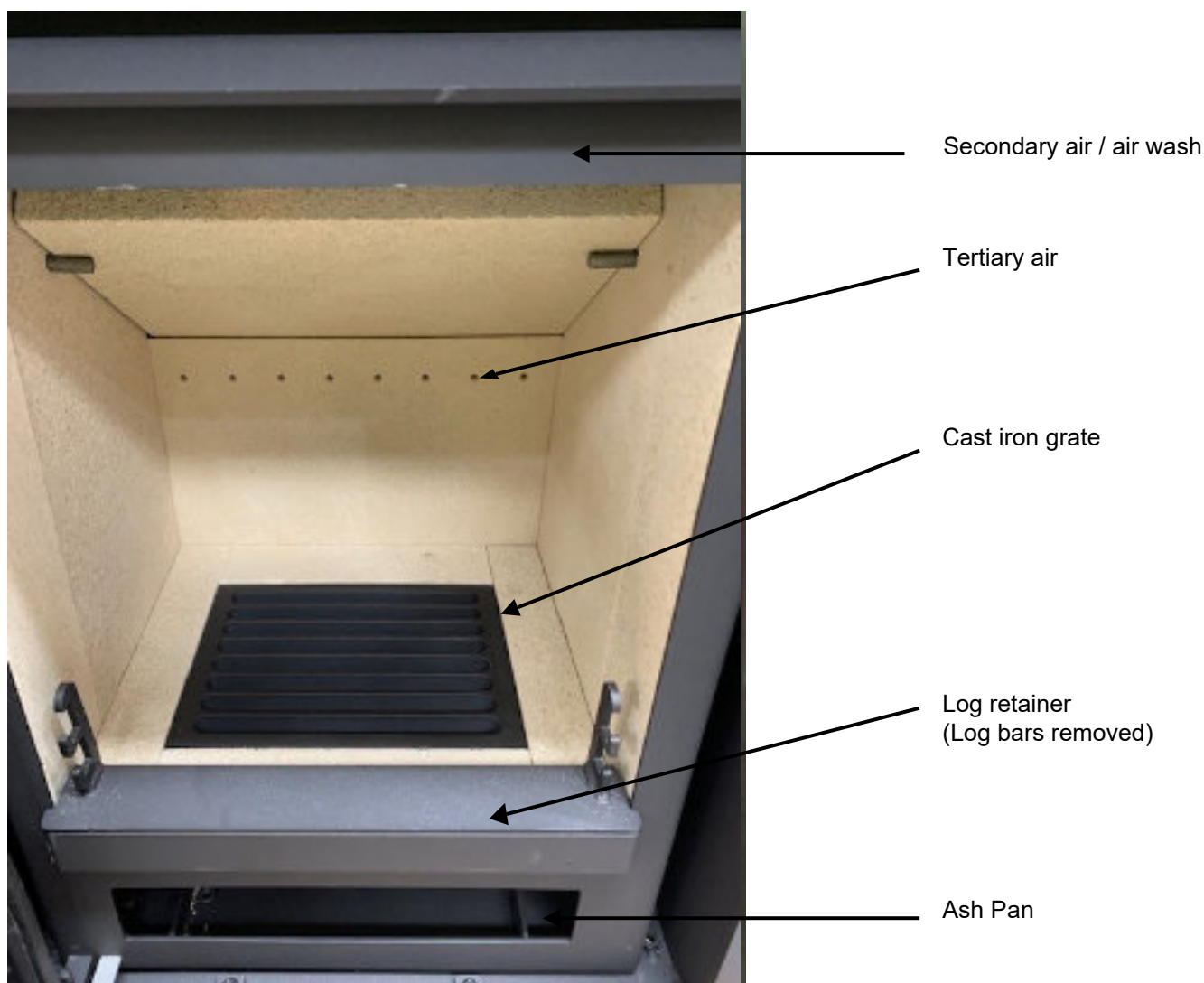

WESTFIRE 35 COMBUSTION CHAMBER

Complete brick set code: W13500-02-00-99-01

WF35

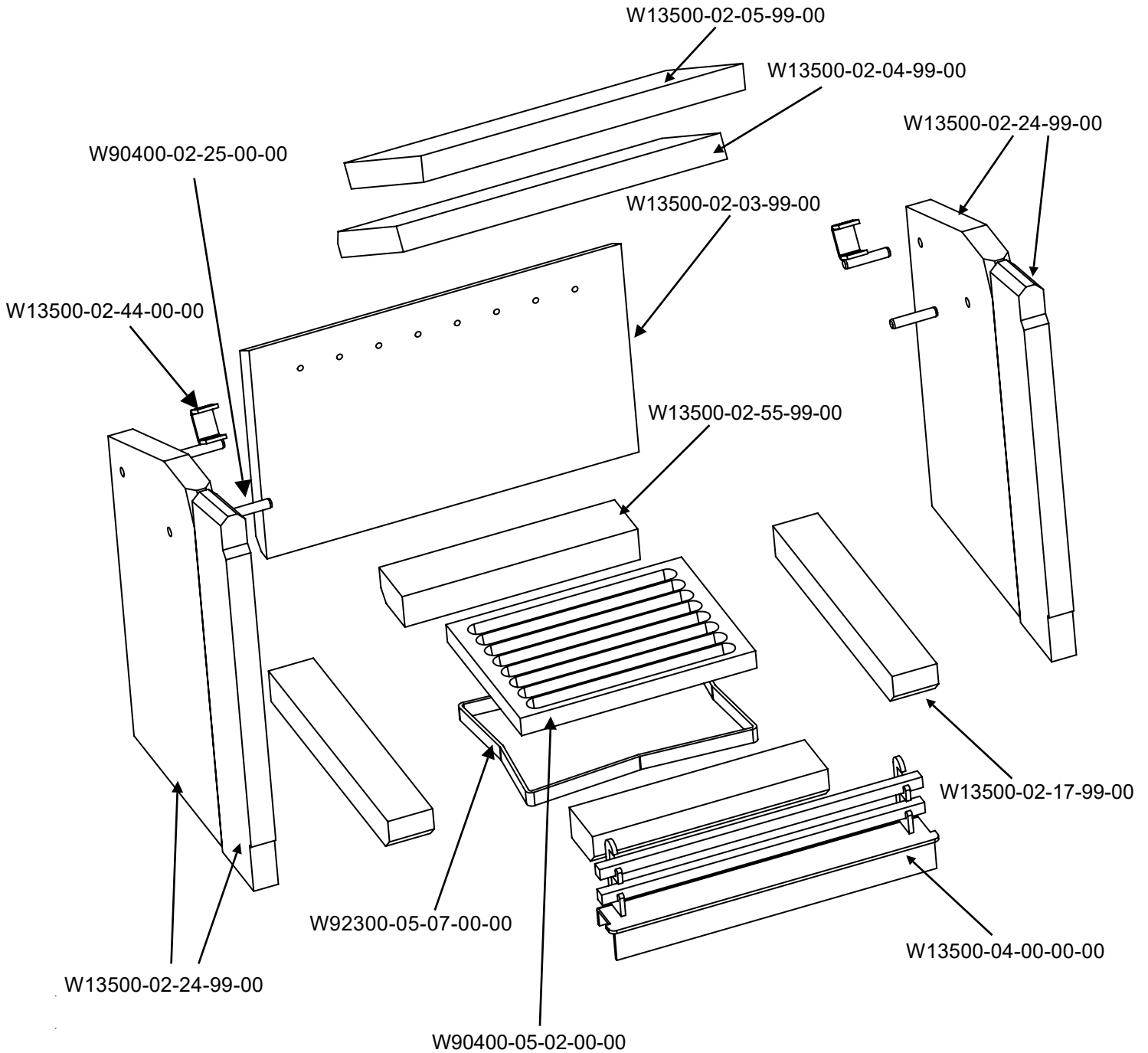

Part	Code	Part	Code
Door Glass	M10540-01-01-99-00	Ashpan	W13500-03-00-00-00
Door rope seal	W13500-06-02-00-00	Handle	M10540-06-04-99-00
Glass rope seal	M10510-01-02-01-00	Tool	W13500-05-05-99-00

HOW TO REMOVE A VERMICULITE BRICK SET



To remove a vermiculite brick set take the following steps.

Ensure the stove is cold before removing brick set.

Remove ashpan and log retainer ,

To remove log retainer lift out individual bars, then lift out metal support section



Remove lower baffle brick, slide baffle plate forward, then allow rear of baffle to drop down until baffle is vertical turn baffle and remove from chamber.

This reveals inner baffle brick above.



Remove inner baffle brick by sliding out inner baffle support brackets on each side, lower baffle to vertical position turn and remove from combustion chamber. Keep these safe as you need to use them again.

HOW TO REMOVE A VERMICULITE BRICK SET



Lift out the grate followed by the grate frame



Remove the 4 firebricks that surround the grate.



Remove side rear left brick then remove side rear right brick.

Remove side right front brick then remove side left front brick.



Remove rear brick.

The brick set is now removed completely, vacuum out chamber and ash pan area before re-installing bricks



DANAK
TEST Reg. nr. 300



**TEKNOLOGISK
INSTITUT**

Teknologiparken
Kongsvang Allé 29
DK-8000 Aarhus C
Phone +45 72 20 10 00

Info@teknologisk.dk

TEKNOLOGISK INSTITUT

Akkrediteret prøvningsorgan, DANAK-akkreditering nr. 300
Notificeret prøvningsorgan med ID-nr. 1235

Prøvningsattest III

Uddrag af rapport nr. 300-ELAB-2436-EN

Emne: Brændeovn; Westfire WF 35

Rekvirent: Westfire ApS
Tømrervej 3, DK-6800 Varde

Procedure:	X	Prøvning efter DS/EN13240/A2:2004
	-	Prøvning efter NS3058-1 & -2 (partikelmåling)
	X	Emissionsmåling af støv og OGC

Prøvningsresultater

Akkrediteret prøvning af brændeovn iht. EN 13240 er foretaget med brænde der påfyres manuelt, og følgende resultater blev opnået:

Nominel ydelse:	4,6	kW
CO-emission:	0.107	% - henført til 13 % O ₂
Virkningsgrad:	78	%
Røggastemperatur:	259	°C
Afstand til bagvæg:	-	se opstillingsvejledning
Afstand til sidevæg:	-	se opstillingsvejledning

Emissioner iht. NS 3058 og/eller CEN/TS 15883:

Partikler efter NS 3058:	-	g/kg (tørstof) middelværdi (krav: ≤4)
Partikler efter NS 3058:	-	g/kg (tørstof) maksimalt (krav: ≤8)
OGC efter CEN/TS 15883:	98	mgC/Nm ³ ved 13% O ₂ (krav: ≤120)
Støv efter DS/EN 16510-1:2018	19	mg/Nm ³ ved 13% O ₂ (krav: ≤30)

Bemærk venligst, at de oplyste værdier er et uddrag af prøvningsrapporten.
For yderligere oplysninger henvises til prøvningsrapporten, se nummer ovenfor.

Westfire 2436 WF 35.docx
22-11-2019 12:49:01

Dette PDF dokument er kun gyldigt, hvis det er digitalt signeret med OCES digitalsignaturen for Kim Sig Andersen, Teknologisk Institut.
This PDF document is only valid if digitally signed with the OCES digital signature for Kim Sig Andersen, Danish Technological Institute.





Product End-of-Life/Recycling:

To dispose of the stove after the product life has expired, please observe the following information.

- Dispose of the items correctly i.e. separate the parts to be disposed of in material groups.
- Always dispose of items in a way that is as sustainable as possible and that is in line with the current environmental protection, reprocessing/recycling and disposal technology.

Distributed by



Distributors of Quality European
Wood Burning Stoves

Eurostove Ltd
Unit H1,
Mendip Industrial Estate,
Mendip Road, Rooksbridge,
Somerset
BS26 2UG

Tel: 01934 750 500

Fax: 01173 156 207

www.eurostove.co.uk

E-mail : info@eurostove.co.uk

